

CHAPTER 7

WATER

CHAPTER 7

WATER

INDEX

<u>Section</u>	<u>Topic</u>	<u>Page</u>
7.0	Water Distribution System	7.1
7.1	General	7.1
7.2	Reference Design Documents	7.2
7.3	Unlawful Connections	7.2
7.4	Minimum Water Distribution Design Criteria	7.3
7.5	Pressure Regulating Valve Installations	7.6
7.6	Sizing of Mains	7.6
7.7	System Layout	7.6
7.8	Alignment and Depth	7.7
7.9	Utility Crossing	7.7
7.10	Easements	7.9
7.11	Future Connections	7.10
7.12	Services	7.10
7.13	Transmission Mains	7.10
7.14	Appurtenances	7.11
7.15	Minimum Acceptable Materials	7.15
7.16	Ductile Iron Pipe	7.23
7.17	Steel Pipe	7.26
7.18	P.V.C. Pipe	7.32
7.19	Reinforced Concrete Pipe	7.35

CHAPTER 7

WATER

INDEX (CONT'D)

<u>Section</u>	<u>Topic</u>	<u>Page</u>
7.20	Fiberglass - P.V.C. Composite	7.36
7.21	Disinfection of Water Mains	7.39
7.22	Acceptance of the Construction	7.44
7.23	Water Services	7.44
7.24	Backflow Prevention Devices	7.50
7.25	Construction Site Restoration	7.53

Graphics

Procedures Flow Chart for Testing Water Mains Meter Sizing
Calculation Form

<u>DRAWING NO.</u>	<u>SUBJECT</u>
W-1	Inside Residential Water Meter Set
W-2	¾" & 1" Water Services
W-3	1½" & 2" Potable Water Meter
W-4 & 4a	Typical PRV Valve Installation
W-5	1½" & 2" Irrigation Meter
W-6	3" & 4" Meter Pit
W-7	6" Meter Pit
W-8	3" & 4" Meter Set with Fire Service
W-9	1½" & 2" Fire Service
W-10	1½" & 2" Meter Set
W-11	Wet Tap Connection
W-12 & 12a	Pressure Reducing Valve Vault

CHAPTER 7

WATER

INDEX (CONT'D)

<u>DRAWING NO.</u>	<u>SUBJECT</u>
W-13	Temporary Blow-Off Assembly
W-14	Air Release Valve and Vault
W-15	Vent Pipe
W-16	Butterfly Valve Installation
W-17	Typical Valve Box
W-18	Meter Pit Cover
W-19	Meter Pit Cover
W-20	Fire Hydrant Assembly
W-21	Fire Hydrant Bollards
W-22	Valve & Hydrant locations
W-23	Water System in Cul-de-sacs
W-24	Stub out Configuration
W-25	Utility Crossing
W-26	Pipe Restraint Table
W-26a	Waterline Lowering Detail
W-26b	Waterline Standard Detail Pipe Clamp
W-27	Wet Tap Connection
W-28	Pipe Encasement
W-29	Anchoring Detail (Concrete)
W-30	Horizontal Bend Thrustblocks
W-31	Typical Vertical Bend Anchors (concrete)

CHAPTER 7

WATER

INDEX (CONT'D)

<u>DRAWING NO.</u>	<u>SUBJECT</u>
W-32	Rod and Clamp Detail
W-33	Marker Post
W-34	Adjustable Pipe Support
W-35	Pipe Casing & Sled Detail
W-36	24" Manhole Ring and Cover

All "SS" Drawings are located in the back of Chapter 10.

7.0 WATER DISTRIBUTION SYSTEM

7.1 GENERAL

All Water Distribution Systems constructed within the Town shall comply with the requirements of these Regulations. These Regulations set forth the minimum design and technical criteria and specifications to be used in the preparation of all water distribution plans, including transmission lines, fire hydrants, backflow prevention devices, valves and other appurtenances. Any special criteria shall be outlined at pre-design meetings, as determined necessary by the Town.

In the case of water mains larger than 12", the Developer shall submit Construction Specifications to the Town for review and approval prior to the Town's approval of the construction drawings.

Primary Standards and Reference Publications used in this Chapter are from:

- American National Standards Institute (ANSI)
- American Water Works Association (AWWA)
- Insurance Service Offices (ISO)
- American Society for Testing & Materials (ASTM)

It is the intent of this Chapter to provide sufficient detailed information to enable the Consultant Engineer to correctly and efficiently design the overall water system for the Project. The water system shall be designated utilizing the most current technical standards along with good, sound engineering judgement throughout the design process. If there is a question or a concern regarding the design of any portion of the water system that is not adequately answered within this Chapter, the Developer shall call the Town's Engineering Division to resolve all issues prior to design. Any variance from these Regulations must be approved in accordance with paragraph 3.2 in Chapter 3 of this Manual.

The design process includes the submittal of the required plan sheets for review and approval by the Town. The water system design shall be an integral part of the plan set requirements as discussed in Chapter 3.

7.2 REFERENCE DESIGN DOCUMENTS

The following documents produced by the listed company or agency are to be used or referenced in the Design of Water Distribution Systems, whether specified or not, it is the intent that the most recent addition or issue of the listed document or specification is considered effective.

<u>Document</u>	<u>Agency/Specification</u>
Ductile Iron Pipe	AWWA C151 (ANSI A21.51)
Ductile Iron Pipe Fittings	AWWA C110 (ANSI A21.10)
Exterior Protective Coatings	AWWA C151
Cement Mortar Interior coatings	AWWA C104 (ANSI A21.4)
Polyethylene Wrapping Specifications	AWWA C105
Specifications for Gate Valves (4"-12")	AWWA C509
Specifications for Gate Vlv. 12" & larger	AWWA C500
Specifications for Butterfly Valves	AWWA C504
Specifications for Type K Copper Tubing	ASTM B88
Coating Specifications for Gate Valves	AWWA C550
Rubber Gasket Joints for Ductile Iron	AWWA C111 (ANSI A21.51)
Standard for Dry Barrel Fire Hydrants	AWWA C502
Composition Bronze or Duncce Mtl. Cstngs.	ASTM B62
Pipe Installation	AWWA C600
Steel Pipe	AWWA C201 or C202
Coal-tar enamel lining research	AWWA C203
Ductile Iron Pipe Rsrch Ass'n (D.I.P.R.A.)	Latest Edition

Any additional AWWA Specifications that apply and are not listed shall also apply and should be referred to for further guidance.

7.3 UNLAWFUL CONNECTIONS

No installation of potable water supply piping or part thereof shall be made in such a manner that it will be possible for used, unclean, polluted, or contaminated water, mixtures, or substances to enter any portion of such piping from any tank, receptacle, equipment, or plumbing fixture by reason of back siphonage, suction, back pressure, or any other cause, either during normal use and operation or when any such tank receptacle, equipment, or plumbing fixture is flooded, or subject to pressure in excess of the main line operating pressure. No person shall make a connection or allow one to exist between pipes or conduits carrying domestic water supplied by the Town and any pipes, conduits, or fixtures containing or carrying water, chemicals, liquids, gases, or any other substances from any other source.

7.4 MINIMUM WATER DISTRIBUTION DESIGN CRITERIA

The Town will generally provide system criteria, however, the following is included as a general guide.

The flows used to design the water system for a particular development vary depending on the type of Development. There are two general categories of Developments for which flow rates are given: Residential Development and Commercial/Industrial Development. Once the specific type of Development is determined, the peak flows are calculated based on average demand, peak day, and peak hour factors. With each type of Development, there is also a unique fire flow that shall be considered when designing the system.

The following Design Criteria for the Town Water Distribution System shall be adhered to.

7.4.1 Land Use Demand Rates.

Residential Single Family (RSF)	400gpd/du(1SFE/du)
Residential Multi Family (RMF)	260gpd/du(0.65SFE/du)
Commercial (COM)	1200gpad(3 SFE/ac)
Industrial (IND)	1200gpad(3SFE/ac)
Institutional (INS)	800gpad(2SFE/ac)
Parks/Irrigated Open Space (PRK)	2000gpad(5SFE/ac)
Churches	600pgd/chu(1.5SFE/chu)
Schools	20gpsd(elem) ,34gpsd(Jr/Sr H)

Elementary (SC1)= 750 students,10 Acres	46.88SFE/sch
Junior High(SC2)=1350 students,15 Acres	114.76SFE/sch
Senior High(SC3)=2200 students,40 Acres	187.0 SFE/sch

Note: All demand rates included irrigation demands and school populations are bases on a year round schedule.

7.4.2 Demand Factors.

Maximum Day Demand/Average Annual Day Demand (MDD) :	2.65
Peak Hour Demands/Average Day Demand (PHD) :	4.5

7.4.3 Fire Flows.

Minimum Residential Fire
Flow (dwellings up to 3,600s.f.): 1,000gpm

Fire flows and duration's for other types of construction shall conform to Appendix III of the Uniform Fire Code.

7.4.4 Storage Requirements.

Storage Volume (mg) = Maximum Day Demand (mg) + NFF (fire volume for duration in mg by service area.)

Note: Due to hydraulic limitations within service areas, fire storage may need to be duplicated. Tank sizing should be based on the ultimate volume required and the availability of suitable sites, but normally greater than 1.0 million gallons.

7.4.5 System Characteristics.

Pressure Zone	Max HGL Elev.	Top Elev. Served	Low Elev. Served	Area Served
---------------	---------------	------------------	------------------	-------------

7.4.6 Hydraulic Performance.

7.4.6.1 Operating Pressures.

Condition	Pressure (psi)
Minimum static pressure (minimum Tank stage)	43
Maximum static pressure (maximum Tank stage)	125

Minimum dynamic pressure

Max day demand + fire flow	20
Peak hour demand	35

1. Condition applies with one critical connecting loop out of service.

7.4.6.2 Head Loss/Velocity.

Maximum velocity with peak hour demands	5fps
Maximum velocity with max Day + fire flows	15fps
Maximum head loss through 16" (transmission)	2.0ft/1000ft
Maximum head loss through 20" (transmission)	1.5ft/1000ft
Maximum head loss 24" and Larger (transmission)	1.0ft/1000ft
Hazen Williams 'C' factor:	120

Note: 'C' factor includes allowances for minor losses and pipe aging.

7.4.7 Minimum Standards for Distribution Piping.

Appurtenance	Minimum Standard
Lines	
Smallest Pipes in network	6 inches
Smallest branching pipes (dead ends)*	8 inches
Largest spacing of 6 inches grid (8 inch Required beyond)	600 feet
Smallest pipes in high value District	8 inches
Smallest pipes in principal streets (business district)	12 inches
Largest spacing of supply mains or feeders	3000 feet
Valves	
Largest spacing on long branches	800 feet
Largest spacing in high value dist.	500 feet

* The following variation from the AWW minimum standards is recommended:

- Branch pipe sizes of 6" will be allowed in short run cul-de-sacs and dead ends (less than 400') provided the fire hydrant spacing meets the requirements of the Uniform Fire Code.

7.5 PRESSURE REGULATING VALVE INSTALLATIONS

Pressure-reducing valve (PRV) installations are used to control pressure between distribution zones. The need for a pressure-regulating valve installation shall be determined by the Town Engineer and shall be based on existing zones and the existing distribution system. Plans shall show PRV stations in the overall layout as well as in the design portion of the plans. The Town's standard details shall be affixed to a detail sheet as necessary.

7.6 SIZING OF MAINS

7.6.1 Distribution Mains. All mains shall be sized large enough to provide for domestic, irrigation, and fire protection flows to the area serviced. The maximum acceptable headloss for 6", 8" and 12" mains is two feet per thousand feet of main. The minimum diameter for water mains in residential areas, including cul-de-sacs, shall be 6". No 10" line sizes are allowed. All schools, shopping centers, business parks, industrial parks, and high-density residential areas shall be looped with mains at least 8" in diameter. All waterlines shall be looped. No dead-end lines except lines extending into cul-de-sacs serving not more than 12 single-family residential units, with a length of no more than 400', will be permitted.

The Town may require oversizing of mains, and the recovery of the costs of such oversizing shall be in accordance with the Town Code.

7.6.2 Transmission Mains. All transmission mains shall be sized in compliance with the Town's Water Master Plan, latest edition.

7.7 SYSTEM LAYOUT

General. All mains shall be installed in dedicated rights-of-way or public easements. Water main

installation in easements between single-family residential lots will only be allowed for the purpose of looping a water main at the end of a cul-de-sac. Under no circumstances should waterlines be installed directly below any concrete such as sidewalks, curbs or gutters. Lines shall normally be located 6' north of the centerline in east/west streets and 6' east of the centerline in the north/south streets, unless otherwise approved, in writing, by the Town. The minimum depth of cover for water mains from the final approved grade of the surface to the top of the water main, shall be 4½'. The maximum depth of cover for water mains shall be 7' below the final approved grade of the surface unless approved otherwise, in writing, by the Town.

Water mains shall be laid a minimum of 10' horizontally from any existing or proposed utility. Upon written approval by the Town, a water main may be laid closer than 10' to a parallel sewer main if it is laid in a separate trench and if the elevation of the invert of the water main is at least 18" above the crown of the sewer main. Water mains shall be designed such that they extend the entire frontage of the property to be served and as approved by the Town.

When the water main passes under a highway or railroad, there shall be a minimum of five feet of cover and a steel casing shall be installed in accordance with the *Standard Details* in these Regulations. The steel casing shall extend the entire width of the right-of-way or easement of the crossing structure or as directed by the Town. In all cases, valves shall be located such that the water main at such crossings can be completely isolated without interruption of any services. When passing under a waterway the water main shall be concrete encased as per the Standard detail in these Regulations.

7.8 ALIGNMENT AND DEPTH

Refer to *Chapter 1* of these Regulations concerning vertical and horizontal separation of water and sewer lines.

7.9 UTILITY CROSSINGS

Construction plans shall show details of the crossings of water distribution lines and all other utility

lines (sanitary sewer, reuse and storm sewer). Water lines will need to be protected by using the concrete blanket detail shown in Drawing No. SS-15 if crossing within 18" top or bottom.

7.9.1 Waterline Crossing over a Sanitary Sewer Line.

When there is less than 18" of vertical clearance between the bottom of the water main and the top of the sanitary sewer, the water main shall be ductile iron pipe a minimum of 10' on each side of the centerline of the crossing. In addition, the sanitary sewer shall be encased in concrete, at each joint, a minimum of 10' on each side of the centerline of the crossing.

7.9.2 Waterline Crossing over a Storm Drain Line.

When there is less than 18" of vertical clearance between the water main and the storm drain, the water main shall be ductile iron pipe a minimum of 10' on each side of the centerline of the crossing. In addition, each joint of the storm drain with 10' of the centerline of the crossing shall be encased in concrete and there shall be a concrete blanket installed in accordance with Drawing No. SS-15.

7.9.3. Sanitary Sewer Line Crossing over a Waterline.

When there is less than 18" of vertical clearance between the water main and the sanitary sewer, the water main shall be ductile iron pipe a minimum of 10' on each side of the centerline of the crossing. In all cases, regardless of vertical clearance, there shall be a concrete blanket installed in accordance with Drawing No. SS-15 a minimum of 10' on each side of the centerline of the crossing.

7.9.4 Storm Sewer Line Crossing over a Waterline.

When there is less than 18" of vertical clearance between the water main and the storm sewer, the water main shall be ductile iron pipe a minimum of 10' on each side of the centerline of the crossing. In all cases, regardless of vertical clearance, the joints of the storm sewer shall be encased in concrete a minimum of 10' on each side of the centerline

of the crossing and there shall be a concrete blanket installed in accordance with Drawing No. SS-15.

7.9.5 Limits on Vertical Separation.

Under no circumstances shall the vertical clearance between any lines involving a waterline, sanitary sewerline, or storm drain be less than 12" without written approval from the Town.

7.10 EASEMENTS

All water mains shall be in an easement that has a minimum width of 20' for one main, 30' in width for two mains, and 40' in width for three mains. Site-specific circumstances may dictate the need for wider easements. The main shall be located a minimum of 10' from and parallel to the edge of the easement. Meters and fire hydrants not installed within the right-of-way will require an easement dedication 10' wide and extending 3' behind the meter or fire hydrant. If the meter or fire hydrant easement is longer than 10', then the width of the easement shall be a minimum of 20'. The fire hydrant shall be centered in such easements. All easements shall be for the exclusive use of the Town. No landscaping (except grass and private irrigation systems), nor permanent structures (mailboxes, sheds, buildings, etc.) shall be placed in the easement.

When requested by the Town any temporary structures (including paving and fencing) placed in the easement shall be removed and replaced by the owner of the land so that maintenance can be performed. The owner of the land shall agree to hold the Town harmless for any replacement of structures removed from the easement.

All easements shall meet the following minimum criteria to provide vehicular access for the Town:

- Maximum cross slope of 4% and a maximum longitudinal slope of 10%.
- No trees or permanent structures may be placed in the easements.
- No easements may straddle property lines, but shall be placed adjacent to the property line, wholly within one of the properties.

7.11 FUTURE CONNECTIONS

A temporary blow-off, in accordance with Drawing No. W-13 of these Regulations, is required at the end of any water main that terminates and is anticipated to be extended in the future. When a future main extension is anticipated, the main shall be valved so that only one valve will have to be closed when the main is extended. The valve shall be restrained so when the one valve is closed and the line to be extended is exposed, the valve will not blow off. No service taps shall be allowed on a main that can be extended in the future between the single valve to be closed and the dead end.

7.12 SERVICES

Unless approved otherwise by the Town each structure shall be, served by a separate service line and meter. No pressure booster facility of any kind shall be allowed on any service line between the public main and the meter. Water service lines shall be located a minimum of 10' away from all sewer services (measured horizontally). All service lines shall be constructed perpendicular to the property line and not more than 5' from the side property line.

All service lines $\frac{3}{4}$ " through 2" shall be Type K copper and shall be installed continuous without joints between the corporation stop at the water main and the meter curb stop. Services shall have a minimum of 4.5' of cover. No service may be located under driveways.

Service connections requiring a flow greater than can be delivered through a 2" corporation and service line shall be either; 3", 4", 6" or 8" connections. Service connections (3", 4", 6" or 8") to new lines shall be made with mechanical joint anchoring tees (swivel tees) or reducing mechanical joint anchoring tees (swivel tee) and installed at the time of main line construction. Later connections, when installed, shall be made with tapping sleeves and tapping valves at the Developer's expense.

7.13 TRANSMISSION MAINS

All water mains 12" and larger in diameter shall be classified as "transmission mains".

All transmission mains shall have air and vacuum release valves installed at all high points on the line, and on each side of butterfly valves in accordance with the detail drawing within the back of this Chapter.

All transmission mains shall have blow-off assemblies installed at all low points on the line, constructed in accordance with the detail drawing within the back of this Chapter.

Valves on transmission mains shall be placed no more than 1,200' apart. Where there are connections to transmission mains, all connecting mains shall be valved at the connection. If the connection main is 12" or greater in diameter, there shall be a minimum of two valves at a tee connection and three valves at a cross connection.

7.14 APPURTENANCES

7.14.1 Valves. All residential and commercial /industrial distribution systems shall be valved to ensure that no more than 600' of main or 18 residential units and 1 fire hydrant will be out of service in the event of a single water main break. Valve placement shall be such that there are at least three valves at every tee and four valves at every cross. Valves larger than 12" shall be butterfly valves. Main line valves shall be located at a point on the main that is intersected by an extension of the side property line of lots in the subdivision.

Under no circumstances shall a valve be located in concrete areas, such as sidewalks, crosspans, aprons, curbs or gutters. Valves located on water mains in easements shall be located at the connecting tee, cross or elbow. Butterfly valve operators shall be located on the right side of the water main in the direction of bells laid. Nay valve located in a greenbelt area shall have a 6" wide by 6 thick concrete collar around the valve box.

Valves shall be located so that any new extension can proceed, be pressure tested, and chlorinated without affecting the existing

system.

Dead-ends on any line that will be tapped for service before being extended shall be provided with temporary blow-off or fire hydrant. Dead-ends on lines that will not be extended shall be provided with permanent fire hydrants at the terminus of the dead end.

Whenever a valve is located outside of a street, walkway, or paved surface, a reference marker shall be installed and noted on the Plans. The reference marker shall be per Drawing No. W-33; within the back of this Chapter.

- 7.14.2 Fire Hydrant Spacing and Location. The maximum distance, as measured along the centerline of the street, between fire hydrants shall be 350' in residential area and 350' in business and other high-value areas unless approved otherwise by the Town. Closer fire hydrant placement shall be required when the fire flow requirements as determined by ISO guidelines exceed 2,000 gallons per minute. Fire hydrants shall not be located within 10' of a curb inlet, Hydrants shall have the "steamer connection" no closer than 18" to finished grade. The base connection of the fire hydrant shall be 6" above rough grade and no less than 4" above finished grade: Hydrants shall be placed on the same side of the street, with locational preference toward street corners that are near available streetlights. A hydrant shall be placed at the beginning of every cul-de-sac. Each section of waterline with a hydrant shall be valved to isolate that hydrant and all hydrants shall have a shut-off valve. All fire hydrant locations and placement are subject to approval by the Town. When hydrants are to be installed at locations other than street intersections, they shall be located at the extension of property side lot lines. In no case shall a hydrant be located closer than 5' to obstructions, driveways, etc. The fire hydrant shall be located within the right-of-way and on the same side of the

street as the water main unless otherwise approved by the Town. Fences, landscaping, etc. shall in no way hinder the operation of the fire hydrant.

Fire hydrant lateral lines shall be set at 90 degrees to mains. The fire hydrant lateral line shall be no more than 70' in length from the main. No horizontal bends or offsets shall be used in fire hydrant lateral lines. Under no circumstances shall any tap be made on fire hydrant lateral line. See paragraph 7.15.6 for materials.

7.14.3 Thrust Blocks. All bends, tees, plugs, dead-ends, wet taps (in certain cases), hydrants, and blow-offs shall be designed and constructed with concrete thrust blocks. If the soil-bearing strength is unknown, the soil-bearing capacity used in design shall be 2,000 pounds/square foot. Refer to the *Standard Details in the back of this Chapter.*

7.14.4 Meters. Meters shall be the same size as the service pipe between the meter and the main. Public water meter installations inside any buildings are allowed as approved by the Town; otherwise, meters shall be located within publicly owned rights-of-way or easements.

All water meters connected to the Town's utility system shall be the property of the Town. Under no circumstances shall anyone other than Town personnel remove a water meter once the pit or vault has been inspected and approved. No connections shall be made in the meter pit other than those related to the meter and bypass. Sprinkler system connections shall be made downstream from the meter and a minimum of five feet from the meter pip or vault. For any installation where special or unusual conditions might exist, detailed drawings, accompanied by a letter of explanation, shall be submitted to the Town for review and approval.

For any water meter installation over 2" in size, detailed drawings of the proposed installation shall be submitted to the Town as part of the Plans.

There shall be no electrical wiring allowed in any water meter pit or vault unless authorized, in writing, by the Town.

All meter sizes for residential, commercial or industrial use shall be, determined by a Registered Professional Engineer in the State of Colorado and calculations submitted to the Town for review and approval. The Consultant Engineer is responsible to follow the procedures as directed in UPC. The Director of Public Works may amend this requirement at his discretion.

7.14.5 Fire Protection Service Line. Valves on newly constructed fire lines shall be located on the tee at the main line. The owner shall maintain all private fire lines beginning at and including this valve. All fire sprinkler taps shall be installed with an approved backflow prevention device and a flow switch that will indicate when water has flowed through the line. A property requiring a domestic service line and a fire protection service line will have separate taps for each. Refer to the Standard Details within the back of this Chapter.

7.14.6 Manholes. Manholes shall be installed on all pressure regulating valves, permanent blow-off installations, and air release valves in accordance with the Standard Detail of these Regulations.

7.14.7 Back-flow Prevention Assemblies. To prevent back-flow contamination of the Town's potable water mains, a back-flow prevention assembly shall be installed where any condition might exist that would result in a higher pressure downstream of the water meter than exists in the main line that could allow back-flow or back-siphonage of polluted or contaminated

water or other substances from the water user's system. The assembly shall be placed downstream of the water meter and installed per Colorado Department of Public Health and Environment Guidelines to allow for proper operation and easy access for annual testing and maintenance. Criteria listed in these Regulations and State guidelines will be used to determine the type of assembly required for each installation based on the potential hazards of the intended use. Some typical applications requiring backflow prevention include hospitals, medical and dental clinics, car washes, dry cleaners, mortuaries, manufacturing processes using chemicals, locations with lawn irrigation systems, buildings with fire protection systems, buildings greater than 40' high and locations with a service line larger than 4" in diameter.

7.14.8 Combination Air Release/Vacuum Valve.

Combination air relief valves and boxes shall be located at all high points in the transmission and distribution system. The combination air relief valves shall be separable from the main by a gate valve and be placed in a cast iron or concrete vault to be shown on the approved plans. As per Drawing No. W-14 within the back of this Chapter.

7.15 MINIMUM ACCEPTABLE MATERIAL

7.15.1 Water Pipe and Fittings: All pipe used in the potable water system shall be D.I.P. (CL-350 or CL-52 and C-151) or P.V.C. (CL-150, C-900, C-950) conforming to the requirements of AWWA, with push-on gasketed joints or mechanical joint ends, in conformance with AWWA C111. All fittings shall be mechanical joint per AWWA. Ductile iron pipe shall be mandatory for mains larger than 8" in diameter. The use of P.V.C. pipe shall be contingent upon approval by the Director of Public Works.

7.15.2 Protective Coatings/Corrosion Protection. The surface finish of all ductile iron pipe shall conform to the following:

- A) Exterior. The exterior coating shall be the standard outside bituminous coating as specified in ANSI A21.6 or ANSI 21.51.
- B) Interior. Normally; no interior coating other than a cement mortar coating as specified in ANSI A21.4 (AWWA C104) will be required.

Casing pipe to be steel 10 gauge, no coating unless specified on the plans, welded butt joints.

7.15.3 Polyethylene. All ductile iron pipe and all fittings shall be wrapped in polyethylene tubing to prevent corrosion. Polyethylene tubing, tape and installation shall meet the requirements of ANSI A21.5 (AWWA C105) and these Regulations. The Town requires visqueen on all ductile iron pipe.

A) Type. All polyethylene encasement for ductile iron pipe and cast iron fittings shall conform to ANSI 21.5-82/AWWA C-105. Polyethylene shall be a minimum of 8 mils thick and the color shall be natural (class A). The encasement may be installed by method A,B or C as described in ANSI 21.5-82 AWWA C-105. Tape shall be PVC, 2" wide minimum, adhesive backed, with a minimum thickness of 10 mils.

- 1) A sealed encasement shall be maintained on the pipe with the polyethylene. The polyethylene shall be taped to existing lines and to the ends of other overlap sections. The sections of polyethylene shall overlap each other by on foot.
- 2) When polyethylene is used, the bedding and backfill shall be controlled so the polyethylene is not torn or damaged. Sand backfill may be required to a depth of 6" above the top of pipe if suitable native backfill material is not sufficient or as deemed necessary by the Inspector.

3) Polyethylene encasement shall also be used at these additional buried locations.

4) Rips, punctures or other damage to the polyethylene encasement shall be repaired with adhesive tape or with a short length of polyethylene, which shall be wrapped around the pipe and secured in place with tape.

a) Valves and fittings with flanged or mechanical joint.

b) Bolted fittings, i.e. couplings.

c) Tie-rods and service connections.

Approved manufacturers: North Town Co., U.S. Pipe or approved equal.

7.15.4 Pipe Casement. Concrete encasement will be required on sewer line when clear vertical distance from water line is less than 1'-6" or horizontal distance is less than 10' between parallel lines. Concrete encasement will be required in all cases where the sewer line is above the water line or is under a waterway crossing. Refer to the pertaining drawings within the back of this Chapter.

Casing for water lines over/under water or structure crossings shall require steel casing of 10 gauge, no coating unless specified on plans with all joints butt welded.

7.15.5 Other Water Pipe Materials: Use of water pipe other than ductile iron pipe or PVC as specified in paragraph 17.5.1 must be approved by the Engineer or Director of Public Works prior to its proposed use in the design. The use of Asbestos Cement Pipe in any portion of the potable water system is not allowed.

All wet taps shall have stainless steel (304) tapping sleeves. Type can be Ford-Fast, Romac-SST, JCM-432 or approved equal.

7.15.6 Fire Hydrant Materials. Fire hydrants shall conform to AWWA C502, be three-way fire

hydrants with a 5' bury. Acceptable hydrant to the Town is Pacer WB-100 by Waterous Co., or super Centurion 20 by Mueller Co. The fire hydrant shall have one 5¼" valve opening, with two 2½" hose nozzles. All shall be AWWA C-502-94. All threads shall be National Standard with 1½" pentagonal cap nuts. All hydrants shall be AWWA C-502-94 standard open left. All hydrants shall be factory-painted red, Federal Standard 595A. See Drawing No's. W-20, W-21, W-22 and W-23.

The mechanical joints of the fire hydrant assembly shall be restrained via all-thread rodding and clamps or meg-a-lug joint clamps, unless more than one section of pipe is used between the hydrant and the valve. For spacing and location see paragraph 7.14.2.

7.15.7 Underground Water Line Valves. All waterline valves shall be manufactured in accordance with applicable AWWA Standards and shall open left. Valve ends shall be mechanical joint. Valves and fittings shall be minimum class 150, unless otherwise required by the Engineer, but never less than the pipe. Sizes 6" through 12" shall be resilient wedge gate valves, M.J., unless specified otherwise on the plans. Sizes 14" and larger shall be direct bury M.J.

7.15.8 Gate Valves: Up to and Including 12". Gate valves without bypass valves may be used on all lines 12" in diameter or smaller. Gate valves shall be of the iron body, non-rising bronze stem, resilient wedge gate type (M.J.) manufactured to equal AWWA Standard C509. The valves shall be double-rise, parallel seat and equipped with "O"-ring stem seals. All stub lines shall be harness-rodded to the main. These valves shall open left and be furnished with a 2" square operating nut or hand-wheel, (where necessary). Valves shall have a full opening flow way of equal diameter of the nominal size of the connecting pipe. The valve disc shall have an integrally cast ASTM B-62 bronze stem nut to prevent twisting or angling of the stem. Coatings shall be equal to or to

exceed AWWA Standard C550 and the specific requirements outlined.

A) All internal and external ferrous metal surfaces shall be fully coated, to a minimum thickness of 4 mils.

B) The coating shall be polyethylene as described in paragraph 7.15.3.

7.15.9 Gate Valves - Larger than 12". Butterfly valves shall be of cast iron body, tight-closing, rubber-sealed, Class 150B, direct buried service conforming to the requirements of AWWA C504 (M.J.). The valve disc shall rotate 90° from full open to full closed position, and the place of the disc in the full seated position shall be 90° to the axis of the pipeline. The valve shall give bubble-tight shut-off against pressure not less than the pressure class of the pipe, see Drawing No. W-16.

7.15.10 Valve Boxes. Valve box shall be equal to Waterous AFC 2500 box (ductile) or Tyler 6860 with a 160 base. With each valve, there shall be furnished and installed a cast iron valve box and cover. The iron valve box shall be substantially made, shall be adjustable for length, and shall be of the screw type. They shall not be less than 5½" in diameter, and the cover shall be of the deep socket type with the word "Water" cast on the top. The protective cover at gate valves shall be increased as necessary to provide a minimum of 5' of protection on the valve bonnet. The base shall not rest on the pipe, see Drawing No. W-17.

7.15.11 Butterfly Valves. Butterfly valves shall be of cast iron body, tight-closing, rubber sealed, Class 150B, buried service conforming to the requirements of AWWA C504. The valve disc shall rotate 90° from full open to full closed position, and the place of the disc in the full seated position shall be 90° to the axis of the pipeline. The valve shall give bubble-tight shut-off against pressure not less than

the pressure class of the pipe.

7.15.12 Combination Air Release/Vacuum Valve.

Combination air relief valves and boxes shall be located at all high points in the transmission and distribution system. The combination air relief valves shall be separable from the main by a gate valve and be placed in cast iron or concrete vault to be shown on the approved plans. The valve body shall be of cast iron, designed for a working pressure of 150 psi, shall be fully bronze-mounted, and shall have 125 pound ASA flanges. The constant pressure portion of the pilot may be either a hydro-mercury control or a spring-loaded control.

7.15.13 Pressure-Reducing Valves.

Pressure-reducing valves, vaults and piping shall be installed in the locations where required by the Town Engineer or Director of Public Works. These valves shall be of a standard type, capable of maintaining any desired constant downstream pressure against a higher and varying inlet pressure. All pressure-reducing valves shall have a pressure-sustaining feature. The Town will provide the approximate upstream pressure to be maintained. Valves shall be furnished with cast iron bodies and covers, bronze trim and copper floats designed for the pressure class of the pipe. The valves shall be placed in a concrete vault and installed with a bypass loop configuration. Use Cla-Val brand only. See Drawing No's. W-4 & 4a and W-12 & 12a.

7.15.14 Pressure Reducing Vault.

Place 6" of 1½" of crushed rock bedding under vault. Two manhole rings to be installed: one is 30" in diameter with frost lid (Neenah R-1757 or equivalent) and other to be 24" manhole ring (See Drawing No's. W-12 & W-12a, W-36 and SS-9).

7.15.15 Air Release Valve And Vault.

APCO 100-C series air relief/vacuum breaker valves shall be used. Air release valve shall be place at the high point of the main water line or as determined through plan review.

7.15.16 Vent Pipe. Vent pipes to be located in the field at the nearest intersection of the street property line and side lot line. Paint pipe safety yellow and locate manhole with distance and directions similar to marker post.

7.15.17 Utility Crossing and Pipe Restraint. Where water line cover exceeds 7'-6" at the low point of the conduit crossing, vertical bends are required. When cover is less than 7'-6", pipe joints may be deflected $\frac{1}{2}$ the manufacturer's recommended on the "as-built" drawings. Multiple joints between meg-a-lug fittings shall be restrained.

See Drawing No's. W-25, W-26, W-26a & 26b for lengths of restrained pipe measured each way from valves and bends and after pertaining details.

7.15.18 Horizontal Bend Thrustblocks. Thrustblock concrete shall have a minimum strength of 3000 p.s.i. All sizes of bends, tees and dead ends shall have concrete thrustblocks. See Drawing No. W-30.

7.15.19 Manholes. Manholes shall be constructed of pre-cast concrete where possible and be asphalt-coated on the inside, when determined necessary by the Director of Public Works or Town Engineer. Concrete pre-cast reinforced risers and tops shall conform to ASTM C-478. Manholes shall conform to the applicable details shown on Drawing No's. SS-1, SS-6 and SS-7. Cones shall be of the eccentric type. Steps for manholes shall be made of aluminum alloy conforming to CDOT Standards, having a minimum tensile strength of 35,000 psi, and have an elongation of not less than ten percent in 2". Steps shall incorporate two non-skid grooves and must, without permanent deformation, carry a load of 1,000 pounds when projected 6" from the wall, and 1,500 pounds when projected 4" from the wall. Plastic inserts must be anchored with no movement. Manholes deeper than 12" shall have a "safety" horizontal platform, (for example, a flat grate with removable cover),

installed at midpoint, to provide an area for refuge and rescue. 18" maximum riser rings are allowed. Openings must align vertically.

7.15.19.1 Mortar for Manholes. Mortar for manholes shall be mixed in the following proportions by volume: one part Portland cement, one-half part hydrated lime, and three parts sand. Masonry cement, ASTM C-91, Type II, if approved by the Engineer, may be used in place of Portland cement and hydrated lime. The cement, lime and sand shall be thoroughly mixed dry and only enough water added to form a mortar of proper consistency. Mortar shall be used within one hour after mixing, with no re-tempering permitted. Mortar that has taken a partial set shall not be used.

7.15.19.2 Manhole Gaskets. Where preformed flexible plastic gaskets are used to seal joints between pre-cast manhole sections, they shall conform to *Federal Specifications SS-S-00210 (6SA-FSS)*, Type I, Rope Form and shall have a minimum diameter of 1½". An approved water stop gasket assembly shall be placed around all pipe that is incorporated within manhole bases, inlet boxes or other concrete structures. The water stop gasket shall be capable of withstanding an internal hydrostatic pressure of 13 psi for 10 minutes without leakage. The word "Water", shall be stamped on the cover.

7.15.19.3 Cast Iron Manhole Covers. All cast iron manhole rings and covers and other iron castings shall be 410lb. cast iron, 23-7/8", ASTM A-48, with a minimum tensile strength of 30,000 psi, (Class 30), Neenah Type R-1706 ring and cover or equivalent, (see

Drawing No. W-36). Castings shall be hot-dipped in asphalt varnish in such a manner as to form a firm and tenacious coating. All metal-bearing surfaces between the ring and cover shall be machined or fabricated to ensure good seating. Manhole lids shall be provided with a non-slip pattern on the surface, which lies flush with the elevation of the ring. Manholes installed outside of the street right-of-way and/or easement shall have locking lid covers. The first two manholes at the exit of a force main shall have locking lid covers.

7.16 DUCTILE IRON PIPE

7.16.1 General. All material, manufacturing operations, testing, inspection and marking of ductile iron pipe shall be in conformity with the requirements of ANSI A21.51-81.

7.16.2 Diameter of Pipe. The diameter indicated on the drawings shall mean the nominal inside diameter of the pipe.

7.16.3 Wall Thickness Design of Pipe. The minimum wall thickness for each section of the pipe line shall conform to ANSI Standard A21.50 for the specified laying condition and for 150 psi minimum working pressure. The following are the minimum allowable thickness' of pipe that may be installed.

<u>Pipe Size</u>	<u>Thickness Class</u>
4"	Class 52
6" & larger	Class 50

7.16.4 Grade of Iron. The grade of iron shall be 60-42-10 having a minimum tensile strength of 60,000 psi, a minimum yield strength of 42,000 psi, and a minimum percent of elongation of 10%.

7.16.5 Pipe Lengths. Pipe sections shall be furnished in not less than 18' nominal lengths, except

bends, reducers, closure pieces, and specials which may be of shorter lengths.

7.16.6 Fittings and Specials. Fittings shall conform to ASA Standard A21.10 (AWWA C110) and may either be cast iron or ductile iron. Fittings shall be class 250 through 12" lines, and class 150 for 16": and larger lines. The designer shall furnish for approval by the Director of Public Works or Town Engineer details of all specials, and other fittings, which are not covered by ASA A21.10. All fittings shall be either flanges or mechanical joints.

7.16.7 Field Joints.

A) Flanged Joints. Flanged joints shall conform to ASA Standard A21.10 (AWWA C110).

B) Mechanical and Push-on Joints. Mechanical and push-on joints shall conform to ASA Standard A21.11 (AWWA C111).

C) Bolts. Bolts for flanged and mechanical joints shall be of Cor-Ten steel by United States Steel, or approved equal.

7.16.8 Protective Coatings. The surface finish of all ductile iron pipe shall conform to the following:

A) Exterior. The exterior coating shall be the standard outside bituminous coating as specified in ASA Standard A21.51 (AWWA C151).

B) Interior. Normally, no interior coating other than a cement mortar coating as specified in ASA Standard A21.4 (AWWA C104) will be required.

7.16.9 Corrosion Protection. Cast and ductile iron pipe and all fittings shall be protected as per paragraphs 7.15.2 and 7.15.3 of these Regulations.

Thickness: 8 mils

Pigmentation: (1) Natural where exposure to ultraviolet light (sunlight,

for example) will be of short duration (less than 48 hrs.).

- (2) The polyethylene material shall be of virgin polyethylene produced from DuPont Alathon resin or U.S.I. Petrothene resin or equal.

Tape: (3) 2" Polyken #900, Scotchrap #50, or approved equal.

A) Installation. Prior to installing polyethylene tubes, clumps of mud or other contaminants shall be brushed off the pipe surface. Polyethylene tubes shall be installed in accordance with ANSI A21.5 Method A. Method A requires the tubes to be overlapped 1 foot and secured with tape, and the slack width to be taken up on top of the pipe and taped at the quarter points. All rips, punctures or other damage to the polyethylene shall be repaired with tape or with a short piece of tubing cut open, wrapped around the pipe and secured in place.

B) Polyethylene tubing may be omitted if soil testing by a qualified Soil Testing Technician indicates a soil resistivity of 2,500 ohms-centimeter or more, and if approved in writing by the Director of Public Works.

7.16.10 Installation. Pipe shall be installed in accordance with AWWA Standard C600 and in accordance with any special requirements of the Town Engineer.

A) Trench Width. The maximum trench width shall be the outside diameter of the pipe plus 3'. Whenever the allowable trench width is exceeded, the Director of Public Works shall be notified, Any improved bedding required by the Town Engineer or Director of Public

Works will be at the expense of the Contractor. There shall be a minimum clearance between the pipe and the trench wall of 8".

B) Bedding. Pipe shall be bedded in accordance with the bedding class noted on the plans. In no case shall the bedding class be less than Class D. Compaction shall be in accordance with Chapter 6 of these Specifications.

7.16.11 Acceptance of the Pipe after Construction. The Contractor shall be responsible for replacing all defective sections of pipe for a period of two years, at no expense to the Town. Defects may be structural in nature or in the form of excess leakage. A Public Works Inspector shall witness each repair or replacement so he can make it part of the permanent record that the defect has been corrected. Final acceptance will be issued at the end of the second year after the initial acceptance and if the line is not defective.

7.17 STEEL PIPE

7.17.1 General. All material, manufacturing operations, testing, inspection and marking of steel pipe shall be in conformity with the requirements of AWWA Standard C201 or C202.

7.17.2 Diameter of Pipe. The diameters shown on the drawings shall mean the outside diameter of pipe sizes under 30": for sizes 30" and larger the diameters indicated shall mean the inside diameter.

7.17.3 Wall Thickness Design of Pipe. The wall thickness of steel pipe shall be designed in accordance with the criteria established in AWWA Manual of Water Supply Practices, AWWA No. M11. The minimum wall thickness for each section of the pipe line, shall conform to that indicated on the drawings, and shall be subject to approval by the Town Engineer or Director of Public Works.

The pipe with stiffeners, if any, and the compacted soil in the bedding section shall form a structure of such stiffness that the vertical deflection of the embedded pipe shall not exceed 2% of the outside diameter of the pipe when subjected to the design loads.

7.17.4 Steel Grade. The grades of steel used in making pipe and fittings shall be those specified in AWWA Standard C201, Grade C, or AWWA Standard C202, Grade B.

7.17.5 Shop Test Pressure. The minimum shop test pressure for pipe and fittings shall be in accordance with AWWA Standard C201 or C202.

7.17.6 Pipe Lengths. Pipe sections shall be furnished in not less than 40' nominal lengths, except bends, reducers, closure pieces and specials which may be of shorter lengths.

7.17.7 Fittings and Specials. Unless otherwise shown on the plans, all fittings shall conform to the dimensions of AWWA Standard C208 for service in piping systems for water works. Pipe used in fittings shall be of the same material and minimum thickness as the pipe. Fittings shall be equal in pressure design strength and shall have the same lining and coating as the abutting pipe. Fittings, unless otherwise shown on the drawings, shall be made of segmentally welded sections, with ends to mate the type of joint or coupling used. Fittings that cannot be mechanically lined and coated shall be lined and coated by hand, using the same materials as are used for the pipe and in accordance with applicable AWWA Standards.

7.17.8 Field Joints. The following types of joints shall be acceptable: welded joints; mechanically coupled joints (Dresser couplings); or push-on joints. Flanges joints shall be acceptable for pipe on supports.

A) Welded Joints. Welded steel pipe joints shall be as indicated in these specifications.

For butt-welded joints, the end of the pipe section being laid shall be carefully aligned with the open end of the previously installed pipe, moved longitudinally until both pipe ends are in contact, and a fitting-up jig attached. For lap-welded slip joints, the spigot of the piece being laid shall be inserted into the bell of the previously installed pipe.

No welding shall be done until the temperature of the pipes connected is uniform and approximately the same throughout their circumference. If necessary to attain this end, welding shall be done at night or the pipes shall be protected from the rays of the sun, or other precautions adopted.

Where welded pipe line joints are used, at intervals of not more than 400', a slip joint shall be provided with 4" longitudinal adjustment, as described under appendix Section A8-1 of AWWA Standard C206.

After the joint is welded, the unprotected area of the pipe shall be cleaned and field lined and coated in accordance with AWWA Standards C203 and/or C205 to the thickness specified for the pipe. At the Contractor's option, cold applied coal tar enamel tape having a minimum thickness of 100 mils may be used to provide the protective coating for field joints. Coal tar tape shall be Protecto Wrap #140 or #200 or other approved similar product. Coal tar tape primer shall be Protecto Wrap #1170 primer or other approved similar product.

- B) Mechanically Coupled Joints shall be Dresser Style 38 or approved equal. The thickness of middle rings shall be the same as that of the pipe on which installed. The grade of steel used shall meet the requirements for steel used for the pipe. Middle rings shall be fabricated to properly fit the outside diameter of the pipe on which installed.

Middle and follower rings shall be cleaned and primed after fabrication. Pipe stops shall not be provided on middle rings of mechanically coupled joints used and adjacent to line valves.

The ends of the pipe on which couplings are to be placed and the couplings themselves, shall be clean and free from any dirt or foreign matter, especially those surfaces of the pipe and coupling that come in contact with the gaskets. Gaskets shall be kept clean with no foreign matter between them and the facing surfaces. Wrenches, used in bolting couplings; shall be of a type and size recommended by the coupling manufacturer. Coupling bolts shall be so tightened as to secure uniform annular space between the follower rings or the housing-clamps and the body of the pipe. All bolts shall be tightened approximately the same amount with all parts of the coupling square and symmetrical with the pipe. After installation, primed couplings shall be carefully touched up or reprimed if required.

Uncoated pipe ends, flanges and couplings shall be primed with Protecto Wrap #1170 and wrapped with Protecto Wrap #140 or #200 or other products approved by the Director of Public Works or Town Engineer.

At locations indicated on the drawings or as directed by the Director of Public Works or Town Engineer, insulating couplings and/or flanges shall be installed in the steel pipe line to facilitate possible future cathodic protection of the pipe line. Insulating couplings shall be Dresser Style 39, or approved equal.

- C) Push-on Joints shall be a stab type joint consisting of a rubber gasketed bell and spigot. Interior dimensions of the joint shall be the same as those of the pipe. Gasket materials shall conform to the

requirements of AWWA Standard C300. The joints shall be designed to remain watertight under all service conditions, including expansion, contraction and earth settlement. The gasket shall not support the entire weight of the pipe. Spigot ends shall have a groove to retain the gasket. Pipe ends shall be self-centering without the aid of the gasket. A rust inhibitive protective coating, which is compatible with the material used for pipe lining, shall be applied to the interior surface of the bell and the exterior surface of the spigot into the bell. After the joint has been made, the exterior shall be primed with Protecto Wrap #1170 primer and wrapped with Protecto Wrap #140 or #200 or other products which have been approved by the Director of Public Works.

The push-on joint shall be, furnished only by a manufacturer experienced in the design and fabrication of joints of this type. Plans and specifications for the joints proposed for use shall be, submitted for approval by the Director of Public Works or Town Engineer.

- D) Flanged Joints for steel pipe shall be fabricated in accordance with AWWA Standard C207. The pressure rating of flanges shall be suitable to withstand the design pressure including allowance for surge pressures. Bolts shall be of Cor-Ten steel by U.S. Steel, or approved equal.
- E) Bond Straps. All "unwelded" joints in the line shall be electrically bonded with bond straps unless otherwise indicated on the drawings or as directed by the Director of Public Works or Town Engineer.

7.17.9 Protective Coatings. The finish surface of all steel pipe shall conform to the following:

- A) Exterior surfaces shall be coated with coal-tar enamel and wrapped in accordance with

AWWA Standard C203. The coating shall consist of coal-tar enamel and bonded asbestos felt wrap. Kraft paper shall be used for final pipe protection. Areas not to be shop coated with coal-tar enamel shall be shop primed.

B) Interior surfaces shall be lined with coal-tar enamel or Portland cement mortar. Coal-tar enamel lining shall be applied in conformity with AWWA Standard C203. Areas which are not to be shop lined with coal-tar enamel, shall be shop primed. Cement mortar linings shall be applied in conformity with AWWA Standard C205. Cement mortar lined pipe shall have an I.D. after lining not less than the specified nominal size.

C) Supplementary Requirements.

- 1) Coal-tar enamel shall have penetration of 15 to 20 at a temperature of 77°F.
- 2) Coal-tar enamel shall have a penetration of 9 or more at the time of application.
- 3) Coal-tar enamel lined or coated steel pipe shall not be exposed to temperatures below 0°F.
- 4) Coal-tar enamel lined or coated steel pipe shall not be handled when the temperature of the pipe is below +25°F. Precaution shall be taken to insure that the temperature of the pipe will never get below 0°F as damage to the lining may occur.

7.17.10 Pipe End Finish.

- A) All pipe ends for mechanical coupled field joints shall be plain in accordance with AWWA Standard C201 or C202.
- B) Pipe end finish for field welded joints shall be in accordance with the requirements of AWWA Standard C201 or C202. Shop applied interior linings and exterior coatings shall

be held back eight inches from the pipe ends.

7.17.11 Installation. Steel pipe shall be installed in accordance with AWWA Manual M11 and in accordance with any special requirements of the Director of Public Works or Town Engineer.

A) Trench Width. The maximum trench width shall be the outside diameter of the pipe plus 3 feet. Whenever the allowable trench width is exceeded, the Director of Public Works shall be notified. Any improved bedding required by the Town Engineer or Director of Public Works will be at the expense of the Contractor. There shall be a minimum clearance between the pipe and the trench wall of 8".

B) Bedding. Pipe shall be bedded in accordance with the bedding class noted on the plans. Compaction shall be in accordance with Chapter 6 of these specifications.

7.17.12 Laying Diagram. Prior to commencement of construction, a laying diagram shall be submitted to the Town for approval on 24" x 36" (bound) sheets. These drawings shall conform to the minimum drafting requirements of the Town.

7.17.13 Acceptance of the Pipe after Construction. The Contractor shall be responsible for replacing all defective sections of pipe for a period of two years at no expense to the Town. Defects may be structural in nature or in the form of excess leakage. A Public Works Inspector shall witness each repair or replacement so he can make it part of the permanent record that the defect has been corrected. Final acceptance will be issued at the end of the second year after the initial acceptance and if the line is not defective.

7.18 P.V.C. PIPE

7.18.1 General. P.V.C. pipe shall only be used for mains not larger than 8" in diameter and when highly corrosive soils are present. Their use will require written approval of the Director

of Public Works. P.V.C. pipe shall comply with paragraph 7.6.1.1 of this Chapter. All installed P.V.C. pipe shall be equipped with detector wire or tape, as approved by the Director of Public Works.

7.18.2 Materials. P.V.C. pipe shall be unplasticized polyvinyl chloride pipe. The pipe shall be suitable for use at maximum hydrostatic working pressures of 200 psi (4 to 1 hydro safety factor) at 73°F. All pipe must meet requirements as set forth in PS22-70, with standard dimension ratio SDR 14 and bearing the National Sanitation seal for potable water pipe. Provisions must be made for contraction and expansion at each joint with a rubber ring, as part of each joint. Pipe and fittings must be assembled with a non-toxic lubricant. Pipe shall be made from clean, virgin, NSF approved class 12454-B P.V.C. Compound conforming to ASTM Resin Specification D1784. Reworked material generated from the manufacturers own pipe production may not be used.

7.18.3 Fittings and Specials. Fittings and specials shall be cast or ductile iron and conform to the pertaining paragraphs of these Specifications.

7.18.4 Testing of Materials. All P.V.C. shall meet or exceed the following tests. All physical and chemical tests shall be conducted at 73°F.

A) Quick Burst Test. The pipe shall be designed to pass without failure a minimum hydrostatic burst pressure of 985 psi applied in 60 to 70 seconds when tested in accordance with PS 22-70 as referenced to ASTM 1599.

B) Sustained Pressure Test. The pipe shall be designed to pass without failure for 1,000 hours a hydrostatic pressure of 650 psi when tested in accordance with PS 22-70 as referenced to ASTM 1598.

C) Acetone Immersion Test. After twenty (20) minutes immersion in a sealed container of anhydrous (99.5% pure) acetone, a 1" long sample ring shall show no visible spalling or cracking. (Swelling or softening is not a failure.) In accordance with ASTM 2152.

D) Drop Impact Test. A single impact load from a freely falling missile having a 2" radius rounded nose shall be imparted on a 6" long section of pipe. No shattering or splitting (denting is not a failure) shall be evident when the following energy is imposed:

<u>Nominal Size</u>	<u>Ft. Lbs.</u>
4"	120
6"	120
8"	120

7.18.5 Diameter of Pipe. The diameter indicated on the drawings shall mean the nominal inside diameter of the pipe.

7.18.6 Storage. P.V.C. pipe shall be stored in a manner which will protect the pipe from damage due to exposure to sunlight.

7.18.7 Sunburned Pipe. P.V.C. pipe which is discolored to any extent, shall be considered as having sunburn damage and shall be rejected and removed from the project.

7.18.8 Installation. Pipe shall be installed in accordance with AWWA Standard C600 and in accordance with any special requirements of the Director of Public Works or Town Engineer.

A) Trench Width. The maximum trench width shall be the outside diameter of the pipe plus 3'. Whenever the allowable trench width is exceeded, the Director of Public Works shall be notified. Any improved bedding required by the Director of Public Works or Town Engineer will be at the expense of the Contractor. There shall be a minimum clearance between the pipe and the trench wall of 8".

B) Bedding. Class C bedding as described in Chapter 6 of these specifications shall be the minimum class of bedding used for P.V.C. Compaction shall be in accordance with Chapter 6 of these specifications.

7.18.9 Acceptance of the Pipe after Construction. The Contractor shall be responsible, for replacing all defective sections of pipe for a period of two years at no expense to the Town. Defects may be structural in nature or in the form of leakage. A Public Works Inspector shall witness each repair or replacement so he can make it part of the permanent record that the defect has been corrected. Final acceptance will be issued at the end of the second year after the initial acceptance and if the line is not defective.

7.19 REINFORCED CONCRETE WATER PIPE, STEEL CYLINDER TYPE PRESTRESSED.

7.19.1 General. All material, manufacturing operation, testing, inspection and marking of concrete water pipe shall be in conformity with the requirements of AWWA C301. Reinforced concrete water pipe shall only be used with the express written consent of the Director of Public Works or Town Engineer.

7.19.2 Diameter of Pipe. The diameter indicated on the drawings shall mean the nominal inside diameter of the pipe.

7.19.3 Wall Thickness Design of Pipe. External loading shall be determined by a combination of dead load and AASHTO HS-20-44 live loading. Trench loading shall be determined by using and E' of 300 psi.

7.19.4 Fittings and Specials. Fittings and specials shall be designed in accordance with AWWA C301.

7.19.5 Joints. Joints shall be in accordance with AWWA C301.

7.19.6 Testing. Testing shall be in accordance with AWWA C600 Section 13, at a pressure specified

on the drawings or contract specifications.

7.19.7 Laying Diagram. Prior to commencement of construction, a laying diagram shall be submitted to the Town for approval on 24"x36" (bound) sheets. These drawings shall conform to the minimum drafting requirements of the Town.

7.19.8 Installation. Pipe shall be installed in accordance with AWWA Standard C600 and in accordance with any special requirements of the Director of Public Works or Town Engineer.

A) Trench Width. The maximum trench width shall be the outside diameter of the pipe plus 3'. Whenever the allowable trench width is exceeded, the Director of Public Works shall be notified. Any improved bedding required by the Director of Public Works or Town Engineer will be at the expense of the Contractor. There shall be a minimum clearance between the pipe and the trench wall of 8".

B) Bedding. Pipe shall be bedded in accordance with the bedding class noted on the plans. Compaction shall be in accordance with Chapter 6 of these specifications.

7.19.9 Acceptance of the Pipe after Construction. The Contractor shall be responsible for replacing all defective sections of pipe for a period of two years at no expense to the Town. Defects may be structural in nature or in the form of excess leakage. A Public Works Inspector shall witness each repair or replacement so he can make it part of the permanent record that the defect has been corrected. Final acceptance will be issued at the end of the second year after the initial acceptance and if the line is not defective.

7.20 FIBERGLASS - PVC COMPOSITE WATER PIPE

7.20.1 General. Composite pipe may be installed only in areas where highly corrosive soils are present and only with the express written consent of the Director of Public Works or the

Town Engineer. Such installations, if authorized, shall be limited to 12" nominal diameter only. All installed Fiberglass - PVC Composite Water Pipe shall be equipped with detection wire or tape, as approved by the Director of Public Works.

- 7.20.2 Materials. Composite pipe shall be constructed of a PVC inner core designed in accordance with ASTM D2996 encased in continuous roving fiber glass. The fiberglass shall be bonded to the PVC with an epoxy resin.

The pipe shall have integrally thickened bell and spigot joints. The pipe shall be rated for use at 200 psi at 75°F with a 4 to 1 safety factor. The standard laying length shall be 20 feet ± 1". Pipe shall be assembled using a non-toxic lubricant. The pipe shall be approved for usage for potable water supply by the National Sanitation Foundation.

The PVC inner core shall be made from clean, virgin, NSF approved Class 13223 PVC compound conforming to ASTM resin specification D1784. Reworked material generated from the manufacturers own pipe production may not be used.

- 7.20.3 Size of Pipe. All pipe shall have an outside diameter equal to that of ductile iron pipe for the specified size of pipe.

- 7.20.4 Fittings and Specials. Fittings and special shall be cast or ductile iron and shall conform to the pertaining paragraphs of these specifications.

- 7.20.5 Testing of Materials. All composite pipe shall meet or exceed the following tests. All test shall be conducted at 73°F ± 3°F.

A) Quick Burst Test. Randomly selected samples which have been tested in accordance with ASTM D1599 shall withstand a hydrostatic test of 1,000 psi when applied in 60-90 seconds.

- B) Sustained Pressure Design. All pipe shall be able to sustain a hydrostatic pressure of 1,000 psi for 1,000 hours when tested in accordance with ASTM 1598.
- C) Minimum Testing Requirement. All pipe shall be 100% hydrostatically tested to 600 psi and held for five seconds.
- D) Drop Impact Test. A 8" long section of pipe shall be subjected to a free falling tup in accordance with ASTM Method Testing D2444. No shattering or splitting shall be evident when the following energy is impacted:

<u>Nominal Size (inches)</u>	<u>12</u>
Ft. - Lbs.	190

- E) Epoxy Cure. A surface area of approximately 1" square on each sample shall be manually worked with a cloth saturated with acetone, for a time period of five minutes. Any evidence of tackiness or solubility of the epoxy will constitute failure.

7.20.6 Physical Properties. Composite pipe shall have the following physical properties:

<u>NOM Size</u>	<u>O.D.</u>	<u>t</u>
12"	13.200	.325

7.20.7 Installation. Composite pipe shall be installed in accordance with AWWA Standard C600 and these Specifications.

- A) Trench Width. The maximum trench width shall be the outside diameter plus 3'. Whenever the allowable trench width is exceeded, the Director of Public Works shall be notified. The pipe shall then be installed as directed by the Director of Public Works or Town Engineer at no additional cost to the Town. There shall be a minimum clear distance of 3" between the trench wall and the pipe.

B) Bedding. The minimum bedding for composite pipe shall be Class C, as described in Chapter 6 of these specifications.

C) Trench Backfill and Compaction. Trench backfill and compaction shall be in accordance with Chapter 6 or these specifications.

7.20.8 Acceptance of the Pipe after Construction. The Contractor shall be responsible for replacing all defective sections of pipe for a period of two years at no expense to the Town. Defects may be structural in nature or in the form of excessive leakage. A Public Works Inspector shall witness each repair or replacement so he can make it part of the permanent record that the defect has been corrected. Final acceptance will be issued at the end of the second year after the initial acceptance and if the line is not defective.

7.21 DISINFECTION OF WATER MAINS

7.21.1 Chlorine Concentration Test. The chlorine concentration shall be tested at accessible locations and as required by the Public Works Inspector. This shall include, but not be limited to, fire hydrants, blow-offs and stub lines. Chlorine shall be tested by either Amperometric Titration¹ of the DPD Test². Orthotolidine colorimetric testing shall not be an acceptable means of testing the chlorine concentration.

7.21.2 Tablet Method. Calcium Hypochlorite Tablets shall only be used for chlorination when contamination control has been exercised during installation of the pipe because the line cannot be flushed prior to chlorination. The tablet method shall not be used when trench water or foreign materials have entered the water line or the temperature is below 5° Centigrade (41° Fahrenheit). The tablets shall

¹ Standard Methods for Water & Wastewater Examination, 14th Ed., 1975, p. 322.

² Ibid, p. 329.

be secured to the pipe wall by use of Permatex No. 1³ or other adhesive, which has been approved by the Director of Public Works. The tablets shall be at the top of the water line after installation of the pipe and the pipe shall be marked to assure that the tablets are so located.

- A) Number of Tablets. After the water line has been filled, the concentration of chlorine, shall be at least 50 milligrams per liter at all test locations. After the line has set for 24 hours, the chlorine concentration shall be at least 25 milligrams per liter. Under normal conditions, the following table should produce the required concentrations using 3¾ grams available chlorine per 5 gram tablet.

NUMBER OF TABLETS

Length of Section(Feet)	<u>Diameter of Pipe(inches)</u>						
	2	4	6	8	10	12	16
13 or less	1	1	2	2	3	5	9
18	1	2	3	4	5	6	12
20	1	2	3	4	5	7	14

- B) Filling the Line. The line shall be filled with potable water at a velocity of less than 1-ft/sec. When the line is full, all Valves shall be operated to insure total chlorination.
- C) Flushing the Line. When the chlorine test has been successfully completed, the line shall be flushed until the chlorine residual is less than 1 milligram per liter. Care shall be taken to prevent erosion or to kill desirable vegetation during flushing procedures.

³ A product of the Permatex Company, Brooklyn, N.Y. and Kansas City, Kansas.

7.21.3 Continuous Feed Method. This method shall be used if it is necessary to flush the water line prior to chlorination or for rechlorination if the tablet method fails.

A) Application of Chlorine. Water from the existing distribution system shall be made to flow at a constant rate through the line to be disinfected. Chlorine is then pumped into the line at the source of fresh water at a rate which will result in a chlorine concentration of at least 50 milligrams per liter measured at all accessible locations and as required by the Utilities Representative. All valves shall then be operated to insure total chlorination. After setting in the line for 24 hours, the chlorine residual shall be not less than 25 milligrams per liter measured at all accessible locations and as required by the utilities representative. The following table should meet these requirements under normal conditions.

CHLORINE REQUIRED TO PRODUCE 50 MG/L
CHLORINE CONCENTRATION PER 100 FT. OF PIPE.

<u>Pipe Size (Inches)</u>	<u>100 Percent Chlorine (Lb.)</u>	<u>1 Percent Chlorine Solution (Gal.)</u>
4	0.027	0.33
6	0.061	0.73
8	0.108	1.30
10	0.170	2.04
12	0.240	2.88

B) Flushing the Line. When the chlorine test has been successfully completed, the line shall be flushed until the chlorine residual is less than 1 milligram per liter. Care shall be taken to prevent erosion or to kill desirable vegetation during the flushing process.

7.21.4 Slug Method. The slug method shall be used for large mains when the continuous feed or tablet methods are not practical.

- A) Chlorine Application. Chlorine shall be applied continuously at a rate so that all interior surfaces will be exposed to a concentration of at least 300 milligrams per liter of chlorine for at least 3 hours. All valves, fire hydrants and blow-offs shall be operated to insure total chlorination.
- B) Flushing the Line. The line shall be flushed until the chlorine residual at all required locations is less than 1 milligram per liter. Care shall be taken to prevent erosion or killing desirable vegetation during the flushing process.
- C) Special Conditions. When water mains are cut into or repaired. Precautions shall be taken to avoid contamination. When it is possible to isolate the section of line, the continuous feed or slug methods of chlorination shall be used, followed and preceded by thorough flushing. The absolute minimum amount of disinfection shall be swabbing all couplings, tapping sleeves and any other materials to be used with a 5 percent Sodium Hypochlorite solutions (commercial Chlorox or equivalent) or a 350 MG/L available Chlorine solution made from Calcium Hypochlorite* just prior to being installed.

7.21.5 Bacteria Test. Following chlorination, all treated water shall be thoroughly flushed from the pipe line at its extremities until the replacement water throughout its length shall, upon test, be proved comparable in quality to the water served the public from the existing water supply system as approved by the Town of Bennett. If there is undesirable bacteria present, the line shall be re-chlorinated as directed by the Director of Public Works.

*One 5g tablet of Calcium Hypochlorite (70% available Chlorine) per 10 liter of water is equal to 350 MG/L of available Chlorine.

7.21.6 Flushing the Line (General). Water lines shall be flushed at a velocity of at least 2.5' per second through the line. Flushing shall be performed after the tablet method but prior to the continuous feed method. Flushing shall always be performed prior to bacterial testing. Flushing of lines will be accomplished by using the pumper nozzle when possible. The side nozzles, when used, must both be used together for flushing purposes.

7.21.7 Testing of Water Mains.

A) Pressure Test. After the pipe has been installed and visually inspected, the trench shall be back-filled. The pipe shall then be filled with water and all air expelled. If hydrants or blow-offs are not available at high points, the Town shall make the necessary taps at high points to expel the air and insert plugs after the air is expelled. The hydrostatic test pressure shall be 200 psi at the lowest point in the line or section under test and shall be maintained for at least one hour. Pressure shall be applied in a manner satisfactory to the Director of Public Works with all testing apparatus furnished by the Contractor.

Leakage shall be defined as the quantity of water that must be supplied into the newly laid pipe, or any valved section thereof, to maintain the specified leakage test pressure after the air in the pipe line has been expelled and the pipe has been filled with water. No pipe installation will be accepted if the leakage is greater than that determined by the formulas:

$$L = \frac{ND \sqrt{P}}{3,700} \quad \text{for mechanical joints and push-on joints; or}$$

$$L = \frac{ND \sqrt{P}}{1,850} \quad \text{for caulked bell-and-spigot joints:}$$

in which L is the allowable leakage, in gallons per hour; N is the number of joints in the length of pipeline tested; D is the nominal diameter of the pipe, in inches; and P is the average test pressure during the leakage test, in pounds per square inch gauge.

7.22 ACCEPTANCE OF THE CONSTRUCTION

Upon completion of all testing, an initial acceptance will be issued and the line will be put into service. The Owner/Developer or Contractor shall then warrant the line and project to be free of defects for a period of two years. Any defects discovered during this time period shall be repaired at the expense of the Contractor or Owner/Developer.

7.23 WATER SERVICES

A) General. Water services shall be designed and constructed in accordance with the specifications contained in this Chapter. The installation of water taps on the water main shall be performed by Department of Public Works personnel and shall be installed at the time of water main construction, after the main has been tested and accepted by the Director. Excavation for water main taps shall be performed by the Contractor. At no time shall a Contractor place water service line taps on a water main. The Contractor shall provide grade stakes for both horizontal and vertical location of all service stop boxes. These grade stakes shall also locate the stop box at a point 5' behind the property line. The Contractor shall be responsible for bedding, backfill, compaction, and maintenance of water service line trenches. Water services shall conform to the Water Service Line and Meter Installation Standard Details.

B) Connections.

- 1) Service water lines 2" or smaller in diameter shall be connected to the water main by means of a bronze corporation stop of the same size as the service line. Service line pipe larger than 2" in diameter shall be connected to the main by a tee connection (wet tap). No underground joints shall be allowed in the copper service pipeline between corporation stop and curb stop. Care shall be

taken to properly install water service lines so that enough slack is in the service lines to protect against pullout problems. Water mains shall be tapped at a 45° angle above the horizontal centerline of the water main on the same side of the pipe as the building to be served.

- 2) Tapping of water mains may require excavating bedding material and cutting or removing part of the corrosion protective polyethylene wrapping. After taps are made, the wrapping shall be repaired or replaced by the Contractor installing the service line in such a manner as to protect both the service line and the water main. Service taps shall have a minimum separation of 24" and be no closer than 24" to a coupling. No more than 4 service taps shall be permitted on any one joint of pipe.

C) Service Saddles, Corporation Stops, Curb Stops.

- 1) Service Saddles. Water service saddles shall be bronze casting with double silicone bronze straps, series 183-0 as manufactured by R.H. Baker and Company; type 323 by Smith-Blair, Inc. or an acceptable equal.
- 2) Corporation Stops. Corporation stops shall be AWWA taper thread to copper connection of pack joint and shall be a Ford Type F-600 or an acceptable equal.
- 3) Curb Stop. A curb stop or valve of the same size as the service pipe and conforming to the following standard shall be installed on every service line between the water main and the meter at a point at or near the property line. Curb stops shall be compression to compression connections and shall be Ford ball valves, B44-666M (1½") or B44-777M (2") or acceptable equal. Curb stop service boxes, shall be a cast iron box, extension type. The curb stop box shall be installed exactly center over the curb stop valve and in a vertical position. The top lid of the curb stop box shall be installed a maximum of 1" above the final grade.

7.23.1 Water Meters and Appurtenances.

- 1) Water meters shall be new, first line quality and of the positive displacement type for cold water service with provision for frost protection and shall be either nutating-disc or oscillating-piston type. Capacity shall be sized for 30 GPM flow, be equipped with magnetic drive, hermetically sealed registers; be readily adaptable to remote cable communication, read-out assemblies design and manufactured for the brand of meter approved for acceptance by the Director of Public Works.
- 2) The body cases of the water meter shall be all bronze construction with manufacturers serial number appearing thereon and shall have raised markings to indicate the direction of flow and the size. All cases shall have a minimum wall thickness capable of withstanding any hydrostatic test pressure of 450 psig. The outer case shall be separable from and allow removal of measuring chambers. The cases shall be of two piece construction sealed by a tamperproof seal wire.
- 3) The measuring chamber of the water meter shall be separate from the outer casing and so secured in the main case that the accuracy of the meter will not be affected by any distortion of the case that might occur when operating under a pressure of 150 psig.
- 4) All water meters shall be provided with strainer screens installed in the meter. Strainer screens shall be of rigid non-ferrous material fit snugly, be easy to remove, and have an effective straining area of at least double that of the main-case inlet.
- 5) Pistons and discs in the water meters shall be smoothly finished. Disc plates, whether flat or conical, shall be either reinforced or equipped with thrust rollers. The piston

and disc spindle shall be securely fastened. Pistons and discs shall be made of vulcanized hard rubber, or a suitable synthetic polymer with specific gravity approximately equal to that of water. The pistons and discs shall have sufficient dimensional stability to retain operating clearances at working temperatures of up to 80°F and not warp or deform when exposed to operating temperatures of 100°F. Piston oscillations or disc notations shall be within 5 percent of the figure recommended in AWWA Standard C700-77 for the size of meter being supplied.

6) The remote register of the water meter shall be enclosed in a freeze proof, temper-resistant enclosure, permit setting or resetting of the register, display a minimum register indication of 100 U.S. gallons on the first wheel and a minimum allowable capacity register of 10 million gallons, display the manufacturers serial number on the dial plate or register enclosure cover, have odometer register numerals not less than 3/16" in height, register not less than 98.5 percent and not more than 101.5 percent of the water actually passed through the meter at any flow rate.

7) The water meter shall produce a low voltage current impulse transmitted via conductor to a remote totalizing register without any source of external power, and activate an eletro-mechanical totalizing register at any location not to exceed 500' from the meter via No. 19 copper wire or larger.

7.23.2 Location and Alignment of Service. Water service lines shall be constructed on the shortest and straightest route possible. At no time shall the service line be any closer than five (5) feet to the side property line, and no service line may be constructed through or in front of any adjoining property. When possible, the service line shall be located five (5) feet toward the high side of the lot from the

centerline of the lot. Water service lines and sanitary sewer service lines shall be at least 10' apart the entire distance from the point of connection to the water and sewer main, to the building. Meter pits or water service lines shall not be located in a driveway or sidewalk.

- A) Meter pits shall not be installed in or under driveways, sidewalks, streets or parking areas.
- B) The meter pit shall be at final grade at the time the meter is to be installed. Final grade may be evidenced by the presence of a curb and gutter.

Any adjustment in the grade of the meter pit, meter yoke or brace shall be by, and at the expense, of the owner.

- C) The meter pit shall be constructed in a workmanlike manner. The rings and hood shall not have spaces between them. The pit shall be free of trash. The meter pit shall have a minimum depth of 4' from finished grade.
- D) The yoke brace (if required) shall be installed on a diameter between the top two rings. The yoke shall be secured in the notch with wire.
- E) Pits shall be vertically plumb.
- F) Hoods shall be raised with riser rings only.
- G) All materials shall be of new quality and free of defects.
- H) Meter pits shall be located away from hazards, I.E., steam vents, electrical equipment.
- I) No lead or field soldered joints are allowed.

J) Backfill around meter pit and in the trench shall be properly back-filled.

K) All bends in the service line shall have a minimum radius of 12".

7.23.3 Materials. All materials used on water service line installations from the water main up to two (2) feet from the building shall be in accordance with this section and the detail sheets.

1) Pipe. All piping shall be installed clean and shall be of the following materials:

A) Copper tubing type "K" either soft temper or hard drawn.

B) Polyethelene pipe shall be in accordance with ASTM D2239-SDR7 PE3406.

i. Ultra high molecular weight material only

ii. 160 psi working pressure

iii. Iron pipe standard only

iv. Must be approved by the National Sanitation Foundation

v. All prior information shall be stamped on the pipe by the Manufacturer.

C) Polybutylene - Class 250 PSI, Iron Pipe Standard only.

7.23.4 Meter Pits. All materials shall not be cracked or damaged in any way. See the detail sheets.

7.23.5 Crossing Sidewalk or Curb (existing or proposed). In no instance, shall a trench extend beneath an existing sidewalk or curb. The pipe must be bored, jacked, or tunneled through the earth under the curb or sidewalk. The trench shall be back-filled according to Chapter 6 of these Specifications.

7.23.6 Service Stub-ins. Service stub-ins shall extend at least to the curb stop or the meter pit. The

meter yoke shall be installed as shown on the standard details.

7.23.7 Service Line Installations. All service line installation work shall conform to the standard details. The Town shall make the physical tap on the water main and furnish and install the water meter. The applicant shall reimburse the Town for the cost of the water meter and for the water service connection, and shall, at his sole expense, provide the trench, service line pipe, meter yoke where required, meter pit or vault, meter pit or vault cover, curb stops, pressure reducing valves where required, and shall install same and backfill trench, all in accordance with the Specifications of the Town of Bennett.

All service connections shall be of uniform size from the service line tap to the building structure or structures. The Public Works Department shall reserve the right to require a larger service connection to any building, structure, or development if the water requirements, when calculated by the fixture unit method as specified in the Uniform Plumbing Code, cause the service line velocity to exceed ten (10) feet per second.

Wherever, in the opinion of the Director of Public Works, or his duly designated representative, a reduced pressure principle back-flow preventer is required to prevent contamination of the public water supply, through a specific service connection, such back-flow preventer of a type and design approved by the Public Works Department shall be furnished and installed, in accordance with the Town of Bennett Specifications.

7.24 BACKFLOW PREVENTION DEVICES

7.24.1 General. Back-flow prevention devices shall be installed on all consumer's water service lines where it has been determined by the Town that a hazardous or aesthetically objectionable condition does or could exist.

7.24.2 Hazardous Condition. A hazardous condition shall mean any unprotected actual or potential connection or structural arrangement between a public or a consumer's potable water system and any other system through which it is possible to introduce into any part of the potable system used water, industrial fluid, gas, or any other substance other than the intended potable water with which the system is supplied.

A) Degree of Hazard. The degree of hazard shall be, determined by the Town, but is generally based on the severity of a health or pollution hazard.

1) Hazardous requires the installation of a reduced pressure principle back-flow prevention device.

2) Aesthetically Objectionable requires the installation of a double check valve assembly, pressure vacuum breaker, or an atmospheric (spring loaded) vacuum breaker.

7.24.3 Approved Models. Only those models that have been approved by the Foundation for Cross-Connection Control and Hydraulic Research, University of Southern California; will be permitted by the Town.

7.24.4 Installation. Each back-flow prevention device shall be installed to the Manufacturers recommendations and these Specifications.

A) Details.

1) Back-flow prevention devices shall be installed on all sprinkler system taps downstream from the meter vault.

2) Installation of back-flow prevention devices will be inside the building or, if an outside installation, they will be above ground and must meet Manufacturers and Town specifications.

- 3) For cases in which the water cannot be shut off for 30 minutes for testing two back-flow prevention devices shall be installed in parallel.
- 4) Installation of a reduced pressure principle back-flow device above electrical or other equipment, where water could cause a hazard, is strictly forbidden.
- 5) All back-flow prevention device pits shall at all times, be maintained by the owner of the pit. Maintenance shall include any work required by the Public Works Department to bring an installation into compliance with the specifications established by the Director of Public Works. On new water services, no meter shall be installed until the installation is in accordance with all specifications. Any deviation from these specifications required written permission from the Director of Public Works. The Director, shall establish the requirements of the deviations.

7.24.5 Testing. When the back-flow prevention device has been installed in accordance with the Manufacturers installation instructions and Town Specifications, the Public Works Department shall inspect and test the device before final acceptance is issued.

7.24.6 Trench Back-fillings. Back-filling shall be in accordance with Chapter 6 of these Specifications with the exception that the compaction test on the service trench must be approved by the Public Works Department prior to patching the street.

7.24.7 Inspection. Public Works Department personnel shall inspect the service line from the main to the meter prior to back-filling in accordance with the specifications. They shall also inspect the service line from the meter to the house, prior to back-filling in accordance with

the specifications.

7.24.8 Discontinuation of Water Service. Whenever a building is torn down or removed, the service line shall be uncovered at the water main and the service corporation closed. A section of the service line, one foot in length, shall be removed at the corporation to physically disconnect the line. If a building permit has been obtained for another building in that location which will utilize the same water service line, the service line will only have to be switched off and locked in the meter pit. A Public Works Inspector shall inspect the disconnection prior to back-filling the hole. Back-filling shall be in accordance with Chapter 6 of these specifications.

7.25 CONSTRUCTION SITE RESTORATION

7.25.1 Work in Improved Areas.

7.25.1.1 General. The Contractor shall restore or replace all removed or damaged paving, curbing, sidewalks, gutters, sod, shrubbery, fences, irrigation ditches, pipe or other structures or surfaces at least equal to the condition before the work began and to the satisfaction of the Director of Public Works. Surplus materials, tools, and temporary structures shall be removed by the Contractor. All dirt, rubbish, and excess earth from excavations shall be disposed of by the Contractor and the construction site shall be left clean and orderly. Construction done on private property shall be restored to a condition at least equal to that before the work began and to the approval of the Director of Public Works. Prior to replacement, all broken edges of paving and concrete shall be saw cut as directed by the Director of Public Works. The subgrade for all restored surfaces shall be thoroughly compacted. The cost of replacement work and removal of all debris from

the site of the work shall be at the expense of the Contractor.

7.25.1.2 Concrete Work. All concrete used in the restoration work including all curb, gutter and sidewalk replacement work shall conform to the requirements set forth in the Town of Bennett, Roadway Design and Construction Standards, or to the requirements of the Street or Highway Department having jurisdiction.

7.25.1.3 Pavement Replacement. All street pavement removed during a day's operation shall be repaired by the end of the day. In lieu of permanent surfacing a 1½" temporary cold mix patch may be installed. Pavement removed on local streets only may be maintained to surface grade with road base material. This may only be done if

- 1) the permanent surfacing is installed within (2) weeks;
- 2) dust or mud does not become a problem; and
- 3) no condition exists which would cause discontent to motorists, pedestrians or residents.

Permanent or temporary surfacing shall be installed and maintained as required by the Director of Public Works. If the Contractor fails to give timely response to the Director's request for installation or maintenance of the surfacing, the Director shall arrange for the required work to be done at the Contractor's expense.

7.25.2 Unfavorable Weather Conditions. Whenever weather conditions are not favorable for permanent surfacing, the Director of Public

Works may require that temporary bituminous cold mix street surfacing 1½" thick be placed over the back-filled and compacted trench in all pave streets and leveled with the existing pavement. This surfacing shall be removed by the Contractor at a later date when weather conditions permit and replaced with permanent hot mix bituminous paving. The permanent work shall not be started until favorable weather conditions exist. As the temporary cold mix surface settles or is displaced by traffic, it shall be replaced immediately and the surface maintained level with the existing pavement until such time as the Contractor is permitted to place the permanent surface.

- 7.25.3 Permanent Street Surfacing. Where applicable, permanent street surfacing shall consist of an approved concrete mix or a hot mix asphalt. The permanent asphalt surface replacement will have an asphalt depth 1" or more greater than the sum of the existing surface course and the base course section, but shall, in no case, be less than 9". If the sum of the existing 12", the Director of Public Works will be notified and the replacement asphalt depth will be installed as required by the Director. The hot mix asphalt surfacing shall be placed in three (3) or more lifts not to exceed 4" per lift. Each lift shall be compacted to a minimum density of 140 pcf. The final lift shall be feathered 1' on both sides of the street cut. All permanent asphalt or concrete work shall conform to the requirements set forth in the Town of Bennett, Roadway Design and Construction Standards, or to the requirements of the Street or Highway Department having jurisdiction. The permanent concrete patch shall be doweled into the existing concrete road surface by means of 16" long #4 rebar sections spaced at intervals of 12".

All manholes and valve boxes shall be brought to final street grade prior to the surfacing.

PROCEDURES FOR TESTING WATER MAINS
 INSTALLED WITHIN THE TOWN OF BENNETT
 (CONTRACTOR IS RESPONSIBLE FOR PROVIDING
 ALL EQUIPMENT AND LABOR NEEDED TO ASSIST
 WITH EACH INDIVIDUAL TEST.)

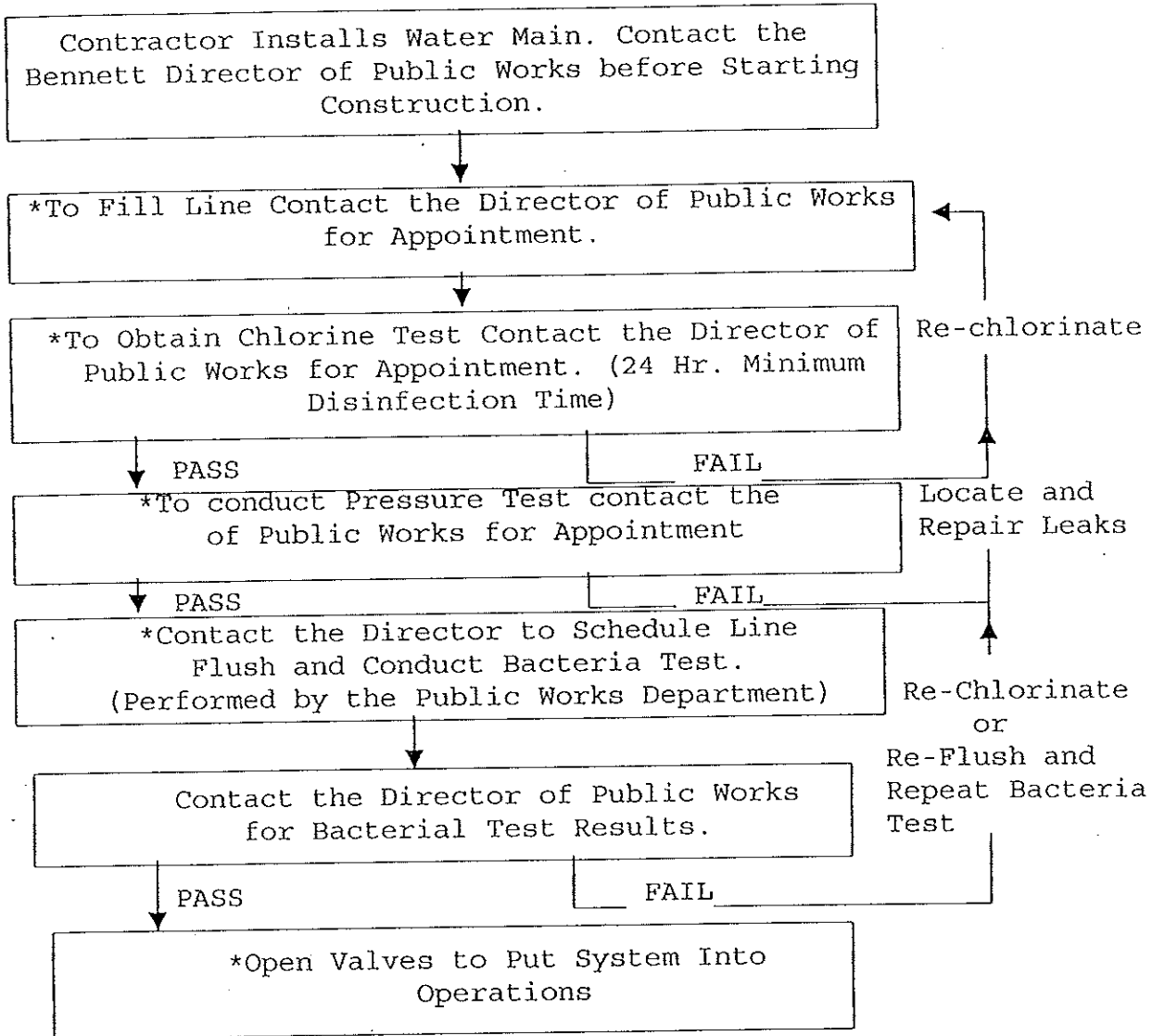

*Any valve separating a Town main and a main system being tested, must be operated by a Town Representative. Contact the Director of Public Works to schedule this operation.

ALL OVERALL WATER CONSTRUCTION PLANS OR ON
THE MECHANICAL DRAWINGS WITH THE BUILDING
PLANS IF SITE PLANS ARE NOT REQUIRED

FIXTURE UNIT TABLE				
METER NUMBER	FIXTURE	NUMBER OF FIXTURES (A)	FIXTURE VALUE (B)	FIXTURE UNITS (A+B)
1	BATHTUB	20	2	40
	KITCHEN SINK	20	2	40
	WATER CLOSET (FLUSH TANK)	20	3	60
	SINK (WASH-UP)	20	2	40
	CLOTHES WASHER	20	2	40
			TOTAL	220
1	LAWN SPRINKLERS	30	1	30
2				

USE LARGER VALUE

METER SIZING TABLE							
METER NUMBER	BUILDING NUMBERS	NUMBER OF UNITS	FIXTURE UNITS *	FLOW (G.P.M.)	METER SIZE IN INCHES **	VELOCITY IN SERVICE ***	CALCULATED PRESSURE AT MOST REMOTE FIXTURE
1	2, 3	20	220	68	2	7.24	45 PSI

* BASED UPON UNIFORM PLUMBING CODE (LATEST EDITION)
 ** MAXIMUM VELOCITY IN ANY SEGMENT OF THE SERVICE LINE IS 10 F.P.S.
 *** METER SIZES SUBJECT TO RE-REVIEW IF TENANT FINISH IS REQUIRED

INSTALL METER WIRE ○ SIDE OF HOUSE NO MORE THAN FOUR FEET BACK AND FOUR FEET OFF GROUND ○ EXTERIOR OF HOUSE. METER WIRE SHALL NOT BE BLOCKED BY FENCE OR LANDSCAPING. LEAVE WIRE LONG ENOUGH TO EXTEND 2' BEYOND EXIT HOLE. WIRE SUPPLIED BY TOWN.

INSTALL METER WIRE INSIDE OF CONDUIT THROUGH FINISHED WALLS & CEILINGS 1/2" EMT TO SYSTEM

TO IRRIGATION
BACKFLOW AS REQUIRED
P.R.V. AS REQUIRED
BALL VALVES

METER YOKE

WIRE FOR TOUCHPAD

METERS WILL NOT BE SET IF CURB STOP BOX IS NOT UP TO GRADE, IF WIRE IS MISSING OR IN WRONG AREA, OR IF AN ASSEMBLY IS NOT IN PLACE.

EXPANSION TANK
CONTAINMENT BACKFLOW PREVENTION ASSEMBLY (DOUBLE-CHECK VALVE ASSEMBLY)

McDONALD TYPE CURB STOP BOX WITH STEM

CORP STOP

CURB STOP

NOTES:

1. BALL VALVE, PN: B21-333
2. METER, SR11 ECR, 5/8" x 3/4", SUPPLIED AND INSTALLED BY THE TOWN (7.5" LAY LENGTH) A PLACE MUST BE SUPPLIED FOR IN FLOOR JOIST TO ACCEPT RADIO READ UNIT AND KEEP KEEP IT ACCESSABLE AT ALL TIMES.
3. BALL VALVE, PN: B11-333 (FORD)
4. PRV
5. APPROVED DOUBLE CHECK VALVE ASSEMBLY, HORIZONTAL INSTALLATION. CALL UTILITIES DEPARTMENT FOR OTHER INSTALLATION ORIENTATIONS. THERE SHALL BE NO TEES PRIOR BE NO TEES. PRIOR TO THIS POINT.
6. NUMBER 2 COPPERHORN PN: CH88-233 (5/8" x 3/4" METER)
7. CURB STOP SHALL BE PLACED ○ PROPERTY LINE.
8. BRASS NIPPLES AS NEEDED.
9. EXPANSION TANK (2 GAL. MIN.)
10. 3/4" TYPE K COPPER -- INSTALLED CONTINUOUS FROM CURB STOP TO COPPERHORN.
11. LINE SIZE FROM TAP ON MAIN TO 10 PIPE DIAMETERS BEYOND ALL TOWN REQUIREMENTS INCLUDING METER MUST REMAIN ONE CONTINUOUS SIZE OF PIPING.
12. BACKFLOW PREVENTION ASSEMBLY INSTALLATION IS REQUIRED PRIOR TO CALLING IN A METER SET.

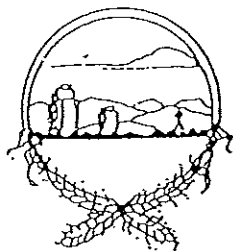

INSIDE RESIDENTIAL WATER METER SET

Town of Bennett

Issued: _____

Revised: _____

Drawing No.

W-1

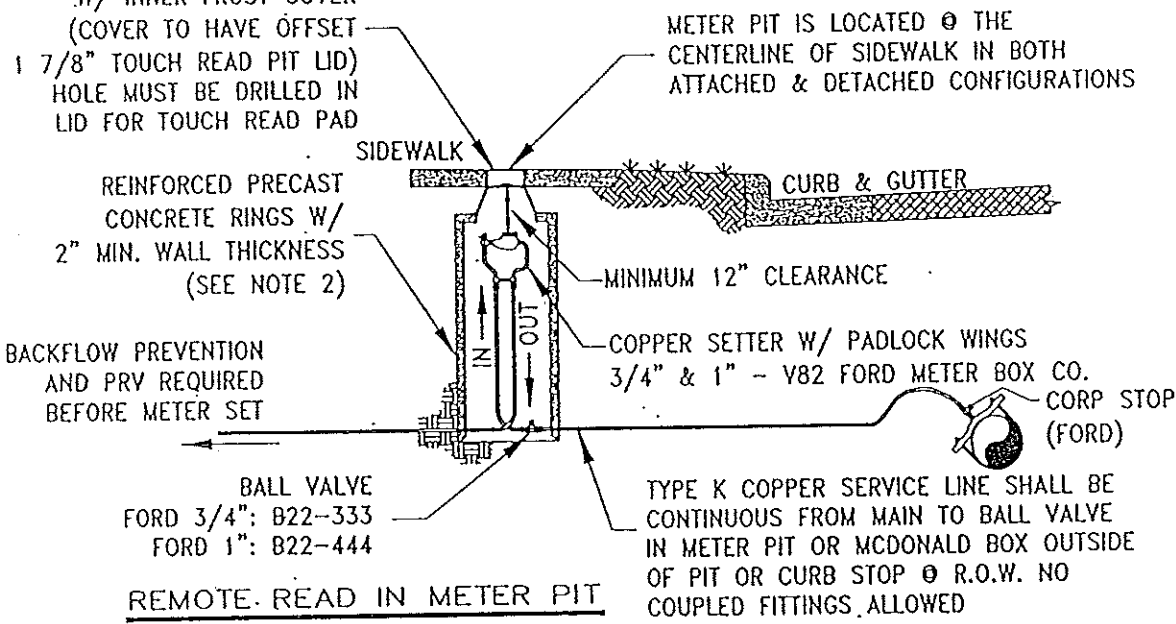
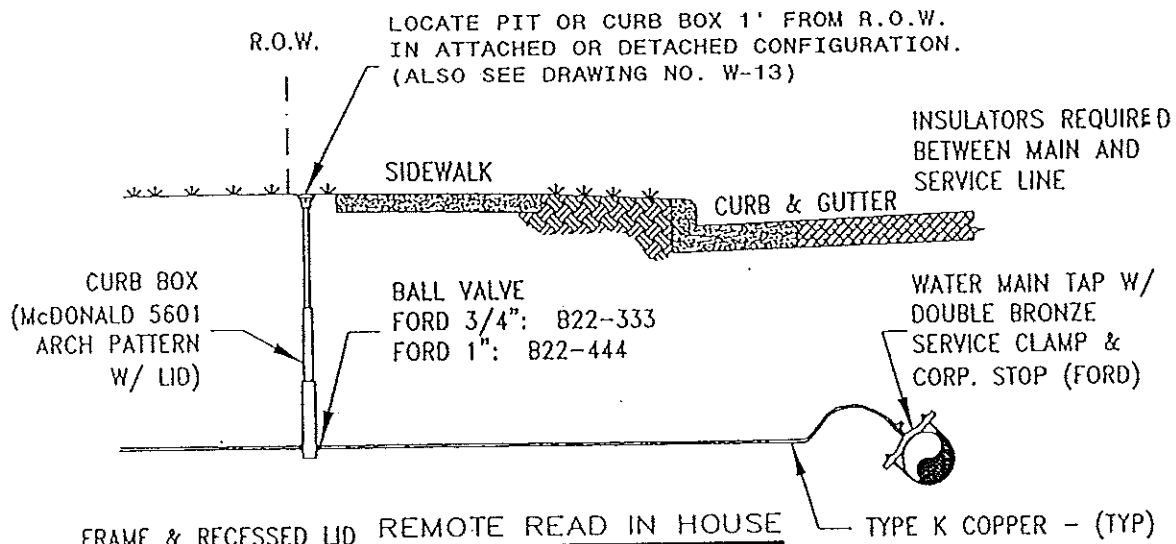

NOTES:

1. ALL SERVICE LINES SHALL BE INSTALLED NEAR THE CENTER OF THE FRONT LOT LINE.
2. METER PITS SHALL BE 20" I.D. FOR 3/4" SERVICE LINES & 24" I.D. FOR 1" SERVICES.
3. LINE SIZE FROM TAP ON MAIN TO 10 PIPE DIAMETERS BEYOND ALL TOWN REQUIRED VALVING, INCLUDING METER, MUST REMAIN THE SAME DIAMETER AS METER.
4. REQUIRED BACKFLOW PREVENTION ASSEMBLY TYPE IS CONTINGENT ON TYPE OF WATER USE, AS DETERMINED BY THE TOWN OF BENNETT'S PUBLIC WORKS DEPARTMENT.
5. ALL TOWN SIDE COUPLINGS TO BE FLARE (NO COMPRESSIONS).
6. THERMAL EXPANSION TANK REQUIRED ON INSTALLATIONS. NOT REQUIRED ON IRRIGATION SERVICES.

POSITIVE DISPLACEMENT METERS LAY LENGTH
$3/4 \times 5/8 = 7 1/2"$
$1" = 10 3/4"$

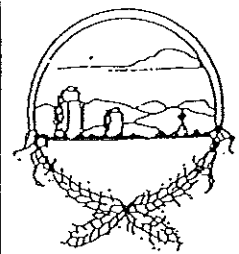

3/4" & 1" WATER SERVICES

Town of Bennett

Issued: _____
 Revised: _____
 Drawing No. _____
 W-2

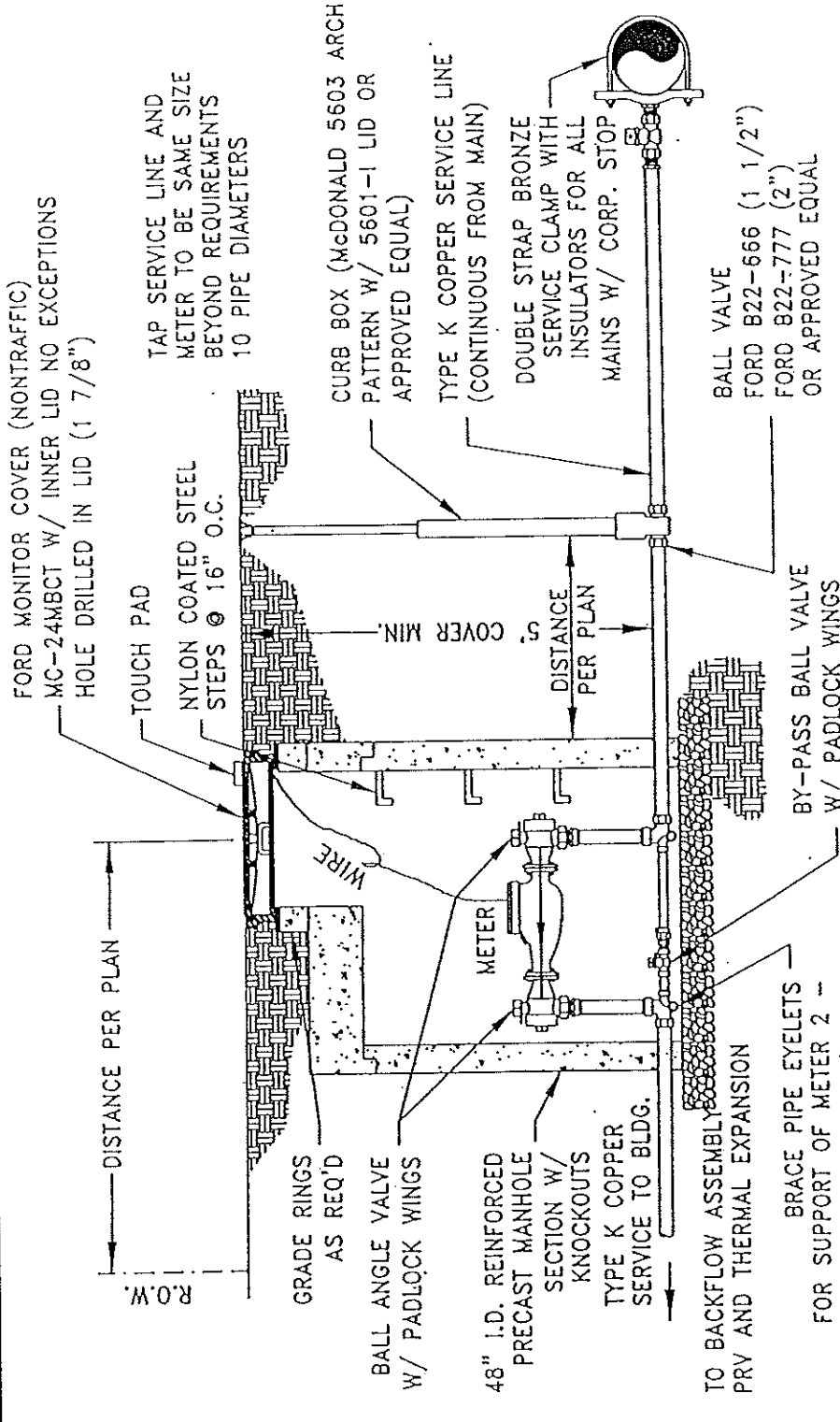

METER LAY LENGTH TABLE *	
1 1/2" METER	2" METER
SR 13"	17"
TURBO 13"	10"
COMPOUND - NA	15 1/4"

* LESS GASKETS

- NOTES:
1. FLANGED METER, SUPPLIED & INSTALLED BY THE TOWN.
 2. FORD 1 1/2" (VBB76-12B-11-66) & 2" (VBB77-12B-11-77) CUSTOMSETTERS W/ 1 1/2" (C28-66) & 2" (C28-77) FLARED COPPER COUPLINGS SHALL BE USED.
 3. THERMAL EXPANSION REQUIRED ON POTABLE SERVICES. NOT REQUIRED ON IRRIGATION SERVICES.
 4. ALL REQUIRED INSTALLATIONS ARE BROUGHT TO GRADE BEFORE METER IS SET.

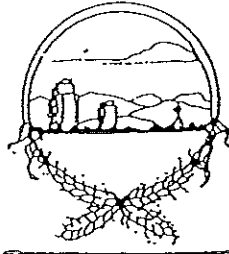

1 1/2" & 2" POTABLE WATER METER

Town of Bennett

Issued: _____

Revised: _____

Drawing No.

W-3

USE MANHOLE GRADE RINGS
(SEE DRAWING NO. W-36)

30" DIA. MANHOLE RING AND COVER W/
FROST LID (HEENAH-R-1757 OR EQUIVALENT)

24" MANHOLE RING & COVER
(SEE DETAIL W-4)

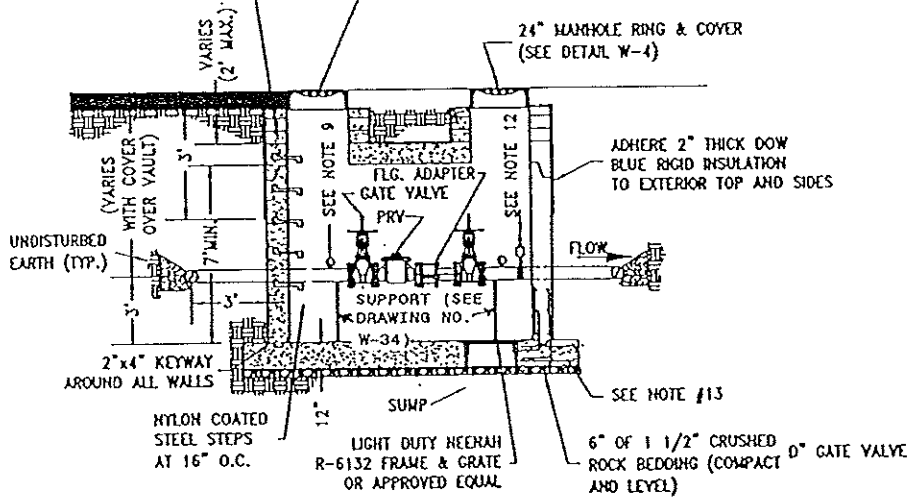

THRUST BLOCK (TYP.)
SEE DETAIL W-9

10' (IF D=8 TO 12 INCHES)
12' (IF D > 12 INCHES)

D2" 90°
ELBOW
(TYP.)

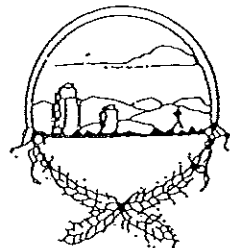
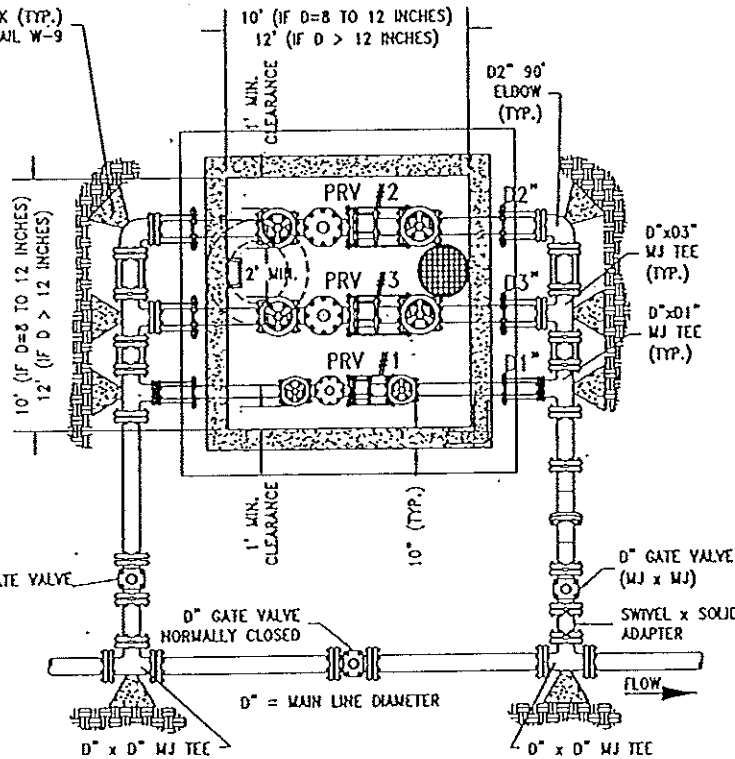

TYPICAL PRV VALVE INSTALLATION

Town of Bennett

Issued: _____

Revised: _____

Drawing No.
W-4

GENERAL NOTES:

1. VAULT SHALL BE DESIGNED FOR HS20 LOADING.
2. VAULT PENETRATIONS SHALL BE SEALED WITH HAMILTON KENT SEAL OR APPROVED EQUAL AND NON-SHRINK GROUT (TYP.)
3. ALL PRV'S TO BE PRESSURE REDUCING/PRESSURE SUSTAINING/CHECK, CLA-VAL OR APPROVED EQUAL.
4. VALVES UPSTREAM PILOT SHALL BE SET TO MAINTAIN 150 PSI MINIMUM. VALVES SHALL BE AS MANUFACTURED BY OCV, CLA-VAL OR APPROVED EQUAL.
5. ALL WORK TO CONFORM TO TOWN STANDARD SPECIFICATIONS.
6. RESTRAINED JOINT SECTIONS OF PIPE SHALL BE RODDED WITH FLANGE LUGS TO PREVENT ANY EXPANSIVE MOVEMENTS.
7. ALL GATE VALVES LOCATED IN THE VAULT SHALL HAVE RISING STEM WHEEL OPERATORS.
8. ALL PIPING SHALL BE FLANGED DUCTILE IRON PRESSURE CLASS 350.
9. PRESSURE GAUGES SHALL BE NON-YELLOWING GLYCERIN FILLED, WITH SNUBBER.
0-200 PSI - 4" DIAL UPSTREAM & 0-100 - 4" DIAL DOWNSTREAM
10. PRV CAPACITY = COMBINATION OF ALL VALVES MUST PROVIDE FLOW EQUAL TO DOWNSTREAM PIPE CAPACITY AT 10 FPS WITH ONE PRV OUT OF SERVICE.
11. MANUFACTURERS REPRESENTATIVE SHALL CERTIFY THE INSTALLATION OF PRV'S.
12. 1-1/2" COMBINATION AIR RELEASE VALVE WITH TAP ON WATER MAIN AND BALL VALVE, DOUBLE STRAP SERVICE SADDLE AND GALVANIZED STEEL PIPE VENT SHALL BE INSTALLED.
13. FABRICATED OR PRECAST CONCRETE VAULT REINFORCEMENT SHALL BE REVIEWED BY THE TOWN ENGINEER.
14. EACH PRV ASSEMBLY SHALL HAVE A MINIMUM OF 2 SUPPORTS NEAR EACH VALVE, (SEE DETAIL W-21)
15. THE FOLLOWING ARE STANDARD SETTINGS. THEY SHOULD BE CONFIRMED WITH THE TOWN FOR EACH VAULT INSTALLATION.

NOTE: PRV PRESSURE SETTING = (PRV #___ GROUND ELEV. - PRV #___ HGL) / 2.31

MAIN DIAMETER (D")	DESIGN FLOW (Ø 10 fps)	PRESSURE REDUCING VALVE/CONNECTING PIPE SIZES			VAULT SIZES
		PRV #1/D1	PRV #2/O2	PRV #3/D3	
8	1600	2"/3"	6"/8"	NA	10'x10'
12	3200	2"/3"	6"/8"	6"/8"	10'x10'
16	6200	4"/6"	8"/12"	8"/12"	12'x12'
18	8000	4"/6"	8"/12"	8"/12"	12'x12'
20	10000	4"/6"	8"/12"	12"/16"	12'x12'
24	14000	4"/6"	12"/16"	12"/16"	12'x12'

DOWNSTREAM PRESSURE ZONE	MAXIMUM HGL	PRESSURE REDUCING VALVE SETTINGS (HYDRAULIC GRADE LINE, FEET)		
		PRV #1 HGL	PRV #2 HGL	PRV #3 HGL
GREEN	6820	6780	6800	6810
RED	6680	6640	6660	6670
PURPLE	6591	6551	6571	6581
BLUE	6520	6480	6500	6510
YELLOW	6349	6309	6329	6339
ORANGE	6192	6152	6172	6182

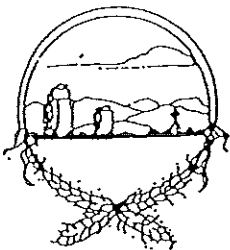

TYPICAL PRV VAULT INSTALLATION

Town of Bennett

Issued: _____

Revised: _____

Drawing No.

W-4a

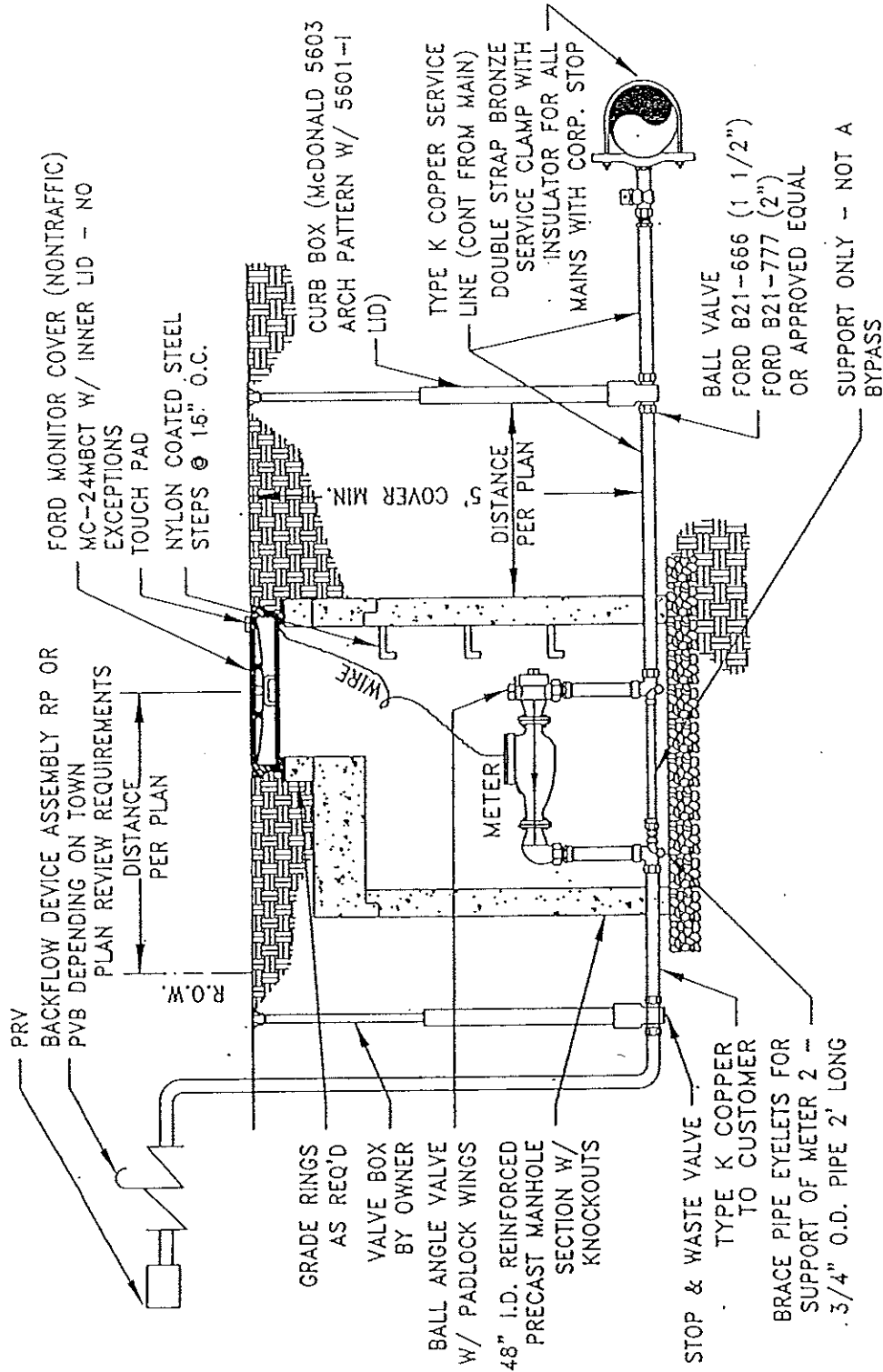

METER LAY LENGTH TABLE *

1 1/2" METER	2" METER
13"	10"

* LESS GASKETS

- NOTES:
1. FLANGED METER, SUPPLIED & INSTALLED BY THE TOWN.
 2. FORD 1 1/2" CUSTOMSETTER V876-12-11-66 & 2-C2866, 2" METER V877-12-11-77 & C28-77 WITHOUT BYPASS.

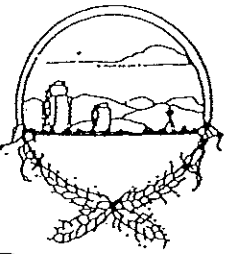

1 1/2" & 2" IRRIGATION METER

Town of Bennett

Issued: _____
 Revised: _____
 Drawing No. _____

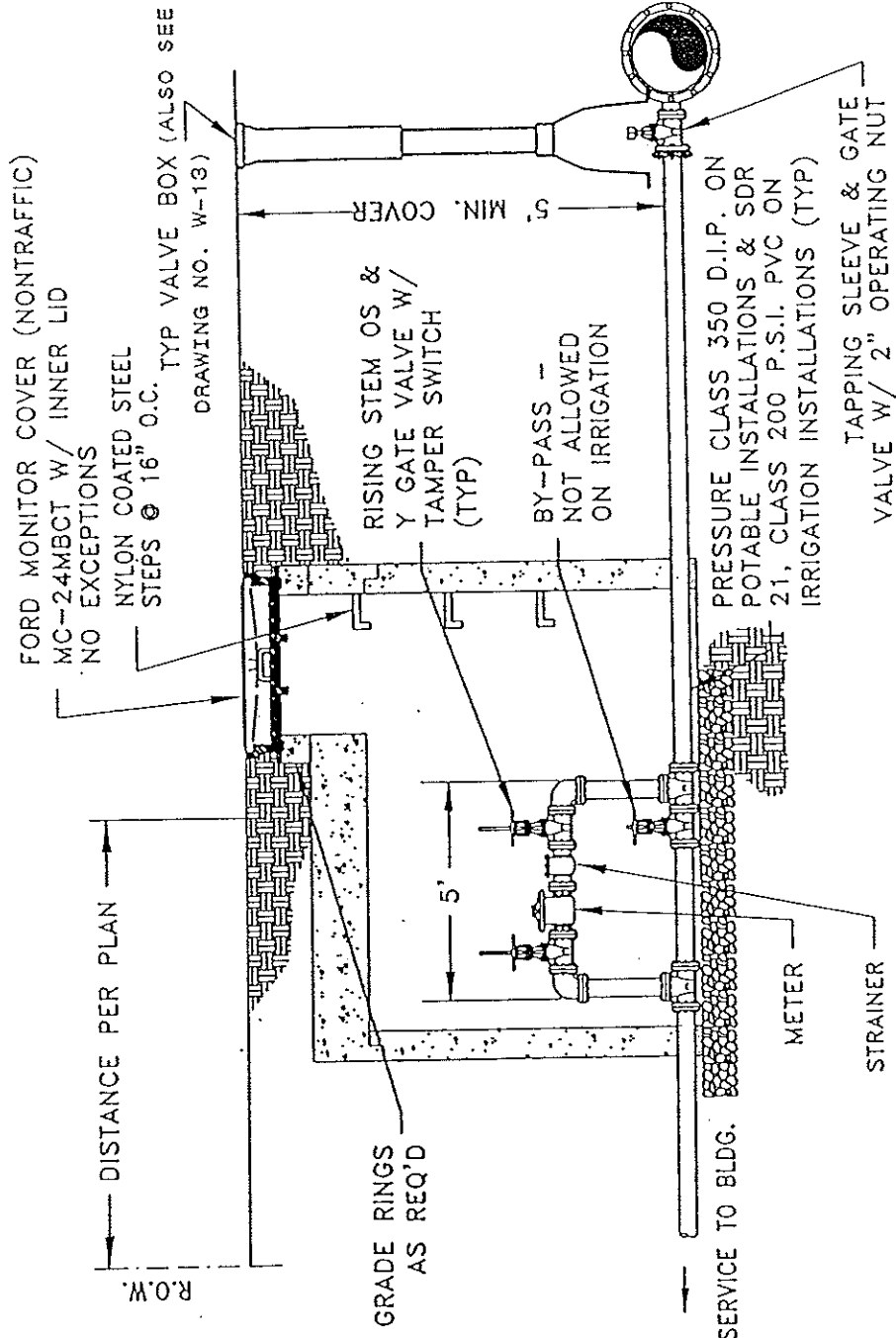

- NOTES:
1. METER SUPPLIED & INSTALLED BY THE TOWN.
 2. IF THE VAULT IS @ A LOW POINT ON IRRIGATION INSTALLATIONS.
 3. VAULT SHOP DRAWINGS TO BE SUBMITTED AT TIME OF PROJECT PLAN APPROVAL.

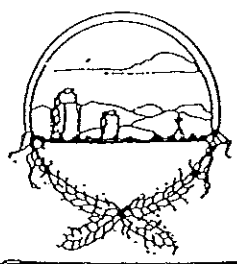

3" & 4" METER PIT

Town of Bennett

Issued: _____

Revised: _____

Drawing No. W-6

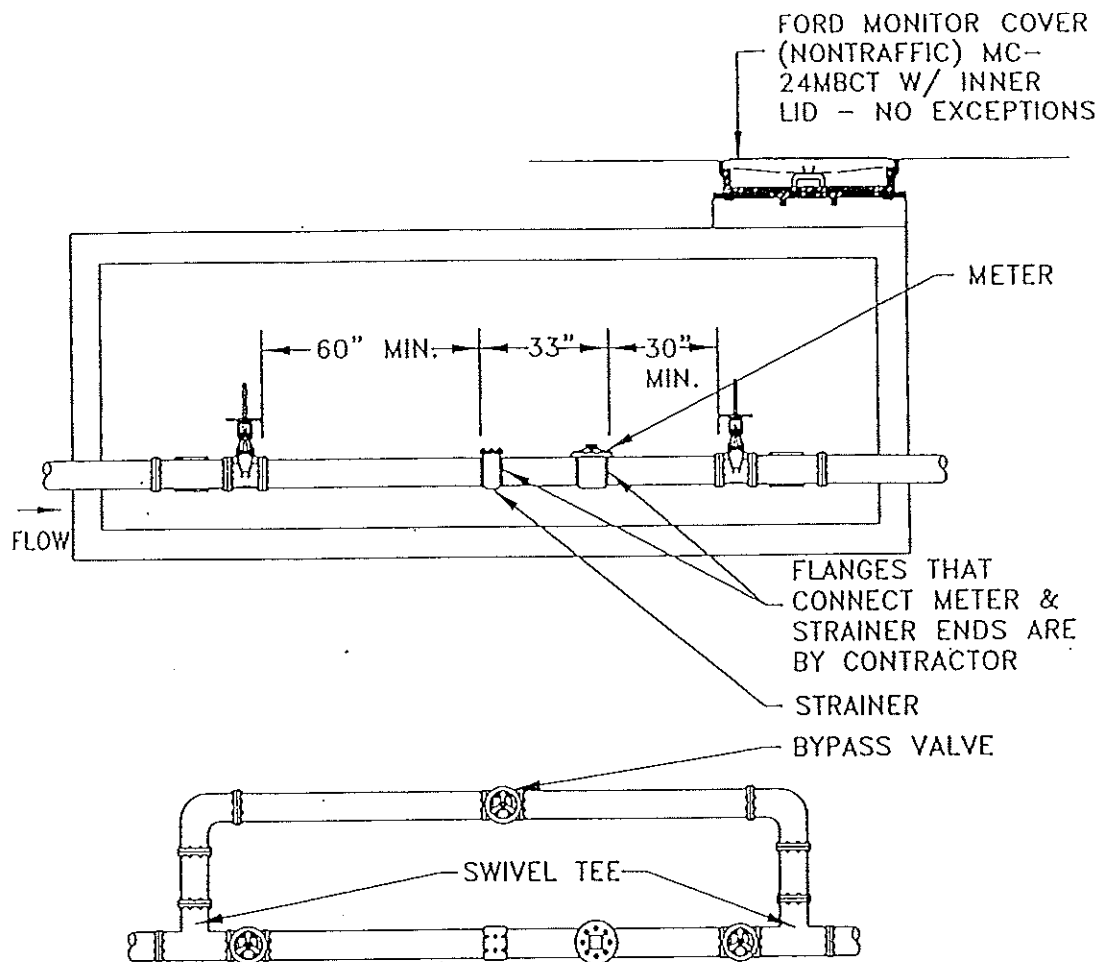

NOTES:

1. VAULT WALL & FLOOR THICKNESS 6".
2. FLANGES THAT CONNECT METER & STRAINERS BY CONTRACTOR.
3. ALL VALVES TO HAVE HAND WHEELS. BYPASS VALVES LOCKABLE OR CHAINABLE.
4. MUST MEET ALL TOWN SPECIFICAITONS.
5. BYPASS VALVE CAN RUN ON OUTSIDE OF VAULT WITH A STREET VALVE.

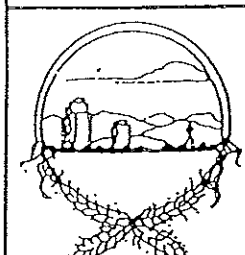

6" METER PIT

Town of Bennett

Issued: _____

Revised: _____

Drawing No.

W-7

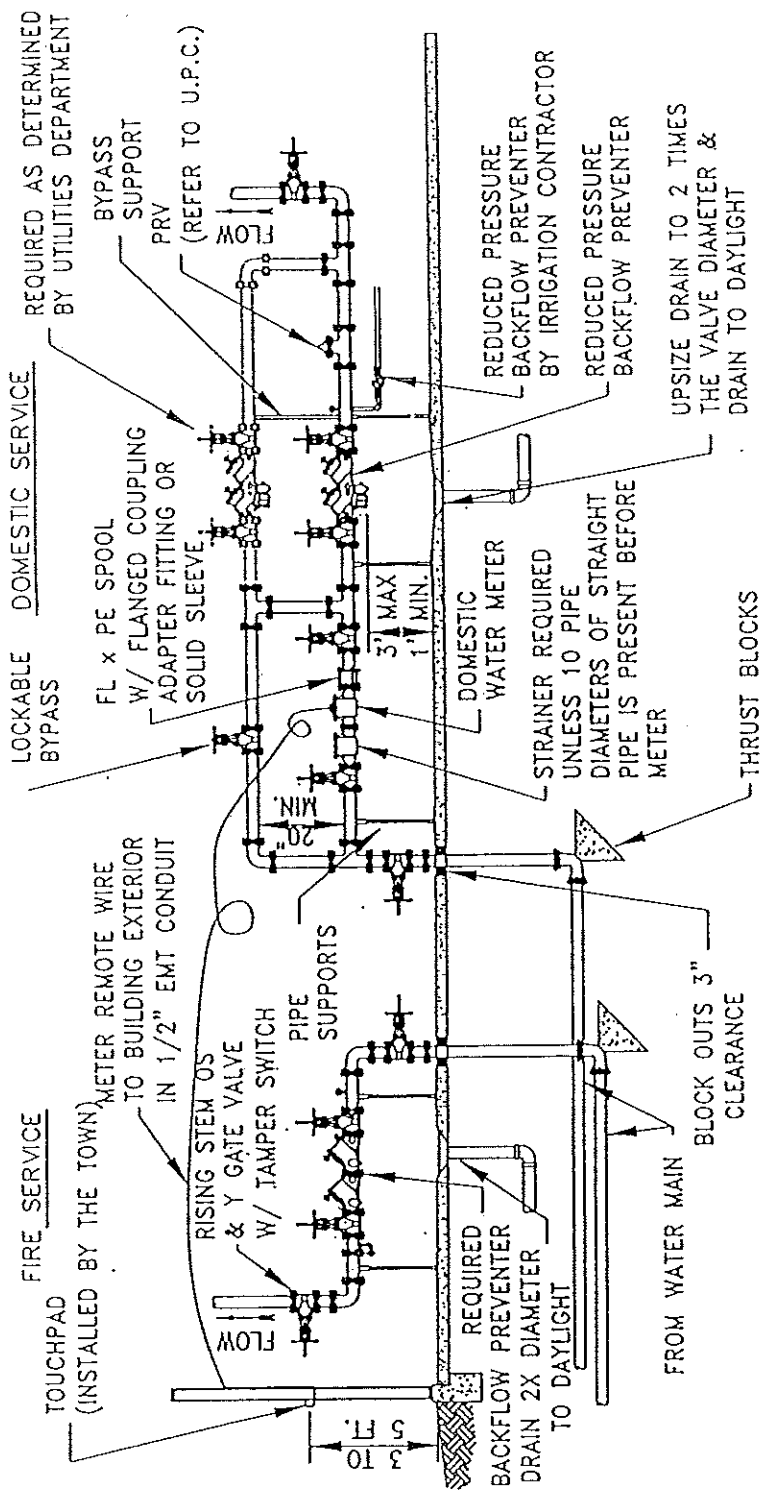

- NOTES:
1. INSTALL METER IN HORIZONTAL PLANE WITH METER SET UPRIGHT ONLY.
 2. VALVES IMMEDIATELY UPSTREAM OF THE METER SHOULD ONLY BE FULL-OPEN GATE VALVES. DOWNSTREAM, FULL-OPEN GATE OR BALL VALVES CAN BE USED. BUTTERFLY VALVES ARE NOT ALLOWED.
 3. TO PROTECT THE METER FROM DEBRIS & TO CONDITION INCOMING FLOWS FROM UPSTREAM FLOW DISTURBANCES, A STRAINER IS RECOMMENDED TO BE INSTALLED IMMEDIATELY UPSTREAM OF THE METER.
 4. DO NOT INSTALL CHECK VALVES OR PRESSURE REDUCING DEVICES LESS THAN TEN (10) PIPE DIAMETERS UPSTREAM OF THE METER AND THREE (3) TO FIVE (5) PIPE DIAMETERS DOWNSTREAM.
 5. ELBOWS, BENDS & NON-CONCENTRIC REDUCERS SHOULD BE A MINIMUM OF TEN (10) PIPE DIAMETERS UPSTREAM OF THE METER, UNLESS STRAINER IS PRESENT.
 6. BACKFLOW PREVENTION ASSEMBLY AND INSTALLATION SHALL CONFORM TO TOWN OF CASTLE ROCK REQUIREMENTS AS IDENTIFIED THROUGH PLAN REVIEW.
 7. ALL GATE VALVES SHALL BE RISING STEM WITH CHAIN & LOCK.

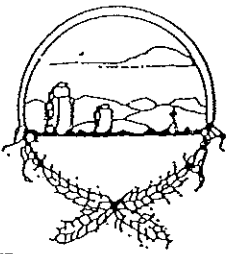

3" & 4" METER SET WITH FIRE SERVICE

Town of Bennett

Issued: _____

Revised: _____

Drawing No. _____

W-8

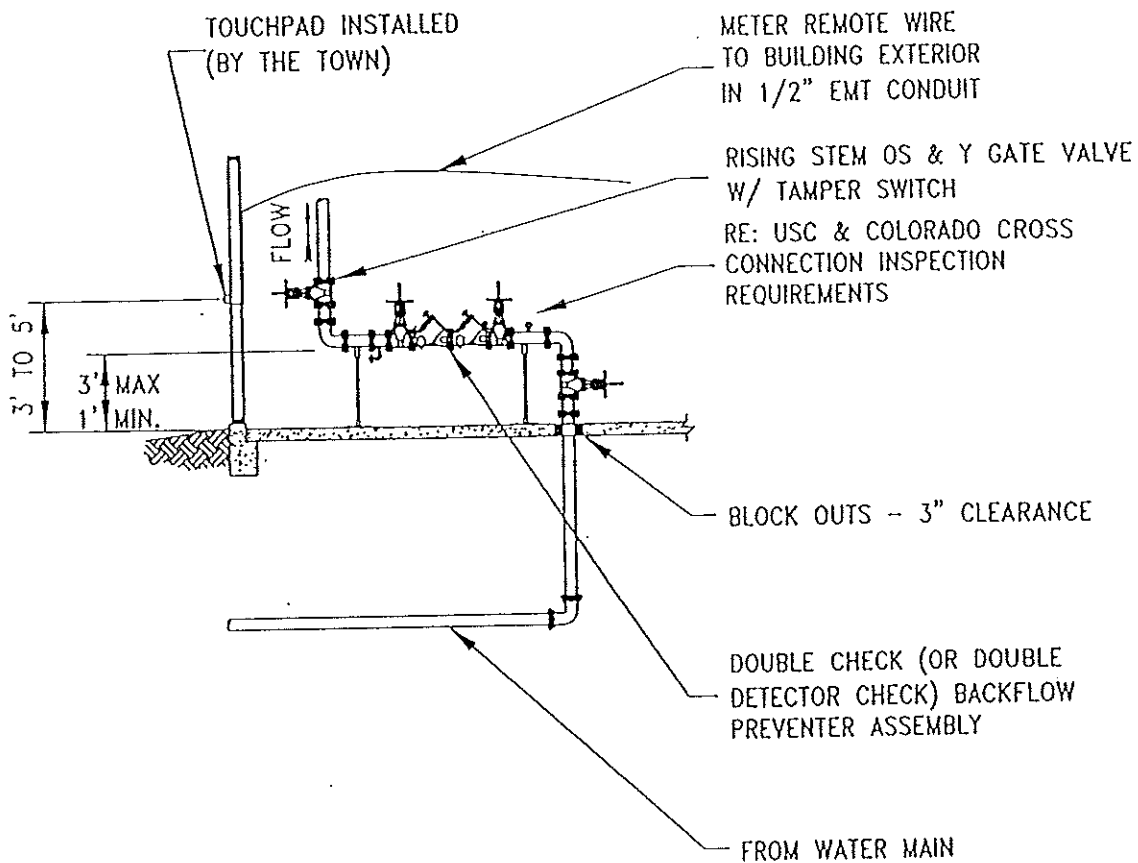

NOTES:

1. 1/4 TURN BALL VALVES WITH HANDLE BYPASS TO BE LOCKABLE.
2. BACKFLOW PREVENTERS SHALL CONFORM TO THE COLORADO CROSS CONNECTION CONTROL MANUAL AND THE FOUNDATION FOR CROSS CONNECTION CONTROL HYDRAULIC RESEARCH FOR PROPER APPLICATIONS, INSTALLATION AND INSPECTION. MINIMUM CLEARANCE 12", MAXIMUM CLEARANCE 36", MINIMUM SIDE CLEARANCE WHEN SIDE LOCK FACES A WALL 24". WHEN TEST LOCKS ARE FACING AWAY FROM WALL MINIMUM CLEARANCE OF 12". NO ELECTRICAL COMPONENTS IN THE SAME GENERAL AREA AS THE BACKFLOW ASSEMBLY.
3. METER INSTALLED AND CONNECTIONS MADE BY TOWN.
4. WIRE SUPPLIED BY TOWN TO BE 3 CONDUCTOR 18 GAUGE.

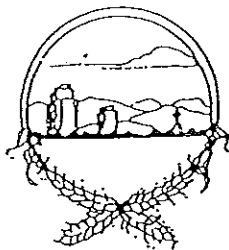

1 1/2" & 2" FIRE SERVICE

Town of Bennett

Issued: _____

Revised: _____

Drawing No.

W-9

METER REMOTE WIRE TO BUILDING EXTERIOR
 IN 1/2" EMT CONDUIT - TOWN PROVIDES
 WIRE - CONTRACTOR TO INSTALL
 BY PASS VALVE TO BE LOCKABLE

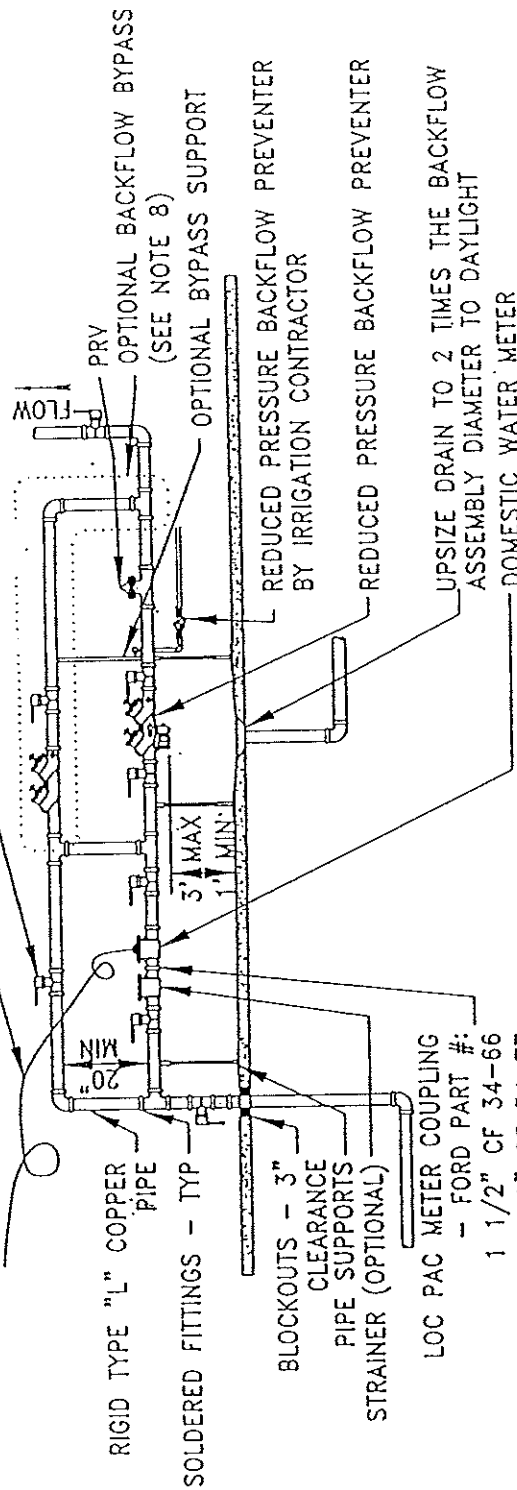

NOTES:

1. INSTALL METER IN HORIZONTAL PLANE W/ METER SET UPRIGHT ONLY.
2. NO GATE OR BUTTERFLY VALVES ON 1 1/2" OR 2" SERVICE. USE 1/4 TURN BALL VALVES WITH HANDLE. BYPASS MUST BE LOCKABLE.
3. TO PROTECT THE METER FROM DEBRIS AND TO CONDITION INCOMING FLOWS FROM UPSTREAM FLOW DISTURBANCES, A STRAINER IS RECOMMENDED TO BE INSTALLED IMMEDIATELY UPSTREAM OF THE METER.
4. ELBOWS, BENDS & NON-CENTRIC REDUCERS SHOULD BE A MINIMUM OF TEN (10) PIPE DIAMETERS UPSTREAM AND 3 TO 5 PIPE DIAMETERS DOWNSTREAM OF THE METER.
5. METER INSTALLED & WIRE HOOK UPS BY TOWN. WIRE SUPPLIED BY TOWN IS TO BE 3 CONDUCTOR 18 GAUGE.
6. BACKFLOW PREVENTION ASSEMBLIES MUST HAVE TEN (10) PIPE DIAMETERS UPSTREAM FROM NEAREST FITTING & THREE (3) PIPE DIAMETERS DOWNSTREAM TO NEXT FITTING.
7. BACKFLOW PREVENTERS SHALL CONFORM TO THE COLORADO CROSS CONNECTION CONTROL MANUAL & THE FOUNDATION FOR CROSS CONNECTION CONTROL HYDRAULIC RESEARCH FOR PROPER APPLICATION, INSTALLATION AND INSPECTION. MIN CLEARANCE 12", MAX CLEARANCE 36" FROM FLOOR. MIN SIDE CLEARANCE WHEN TEST COCK FACES A WALL 24". WHEN TEST COCKS FACE AWAY FROM WALL MIN CLEARANCE 12". NO ELECTRICAL COMPONENTS IN THE SAME GENERAL AREA AS THE BACKFLOW ASSEMBLY. CONTRACTOR TO PROVIDE PASSING TEST RESULTS ON ALL BACKFLOW PREVENTERS TO DEPARTMENT OF UTILITIES.
8. IF BYPASS IS NECESSARY FOR CONTINUOUS WATER SERVICE DURING METER AND/OR PRIMARY B/F ASSEMBLY REPAIR, TESTING OR MAINTENANCE, B/F ASSEMBLY IS REQUIRED ON BYPASS.

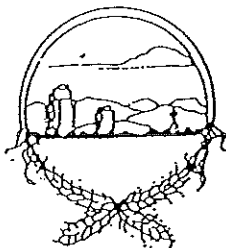

1 1/2" & 2" METER SET

Town of Bennett

Issued: _____

Revised: _____

Drawing No. _____

W-10

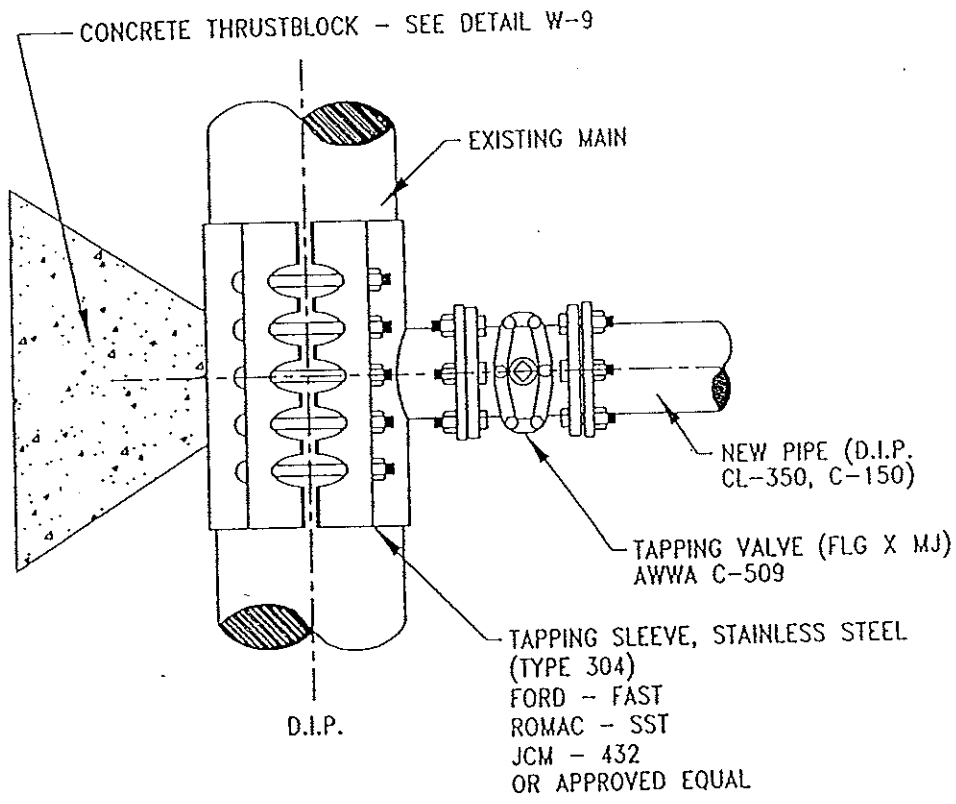

NOTES:

1. THE TOWN SHALL BE NOTIFIED AT LEAST 48 HOURS PRIOR TO TAPPING. THE TOWN'S REPRESENTATIVE SHALL BE ON SITE DURING TAPPING.
2. WET TAPPING DETAIL IS FOR USE ON DUCTILE IRON PIPE.
3. SIZE x SIZE WET TAP CONNECTIONS WILL NOT BE ALLOWED.

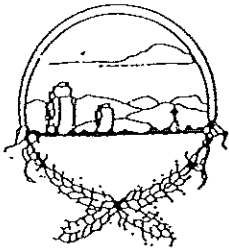

WET TAP CONNECTION

Town of Bennett

Issued: _____

Revised: _____

Drawing No.

W-11

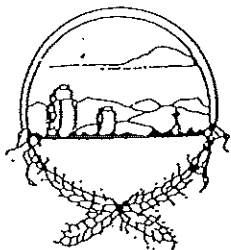

PRESSURE REDUCING VALVE VAULT

Town of Bennett

Issued: _____

Revised: _____

Drawing No.
W-12

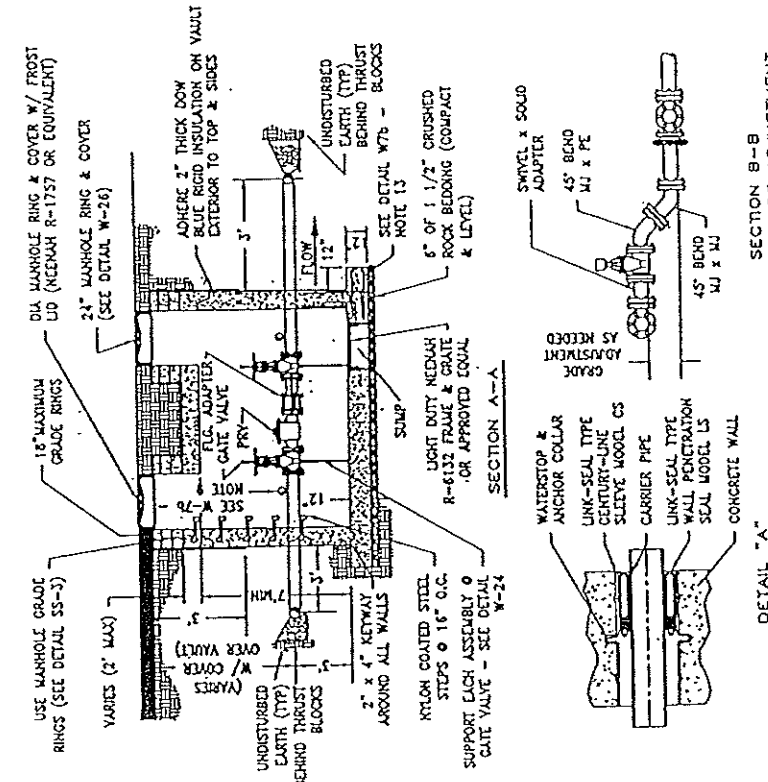
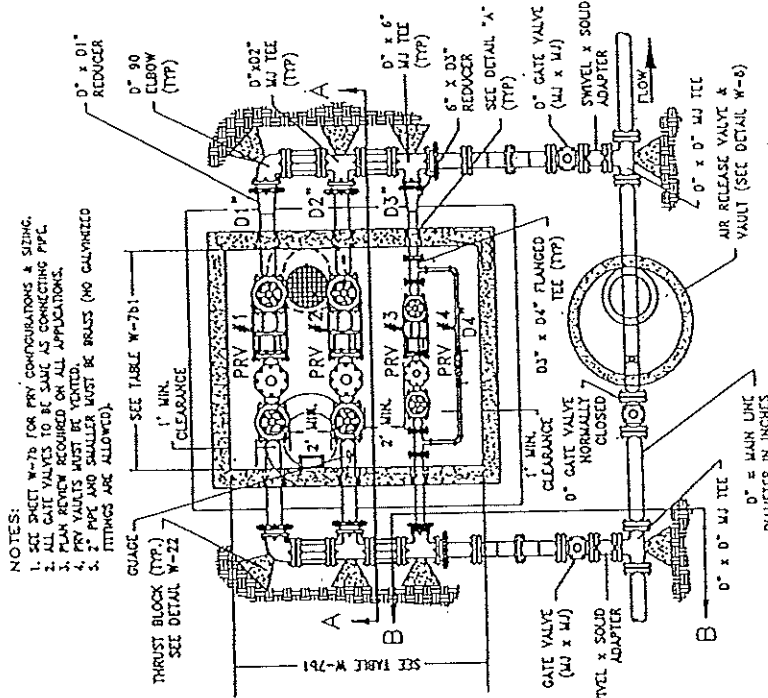

- NOTES:**
1. SEE SHEET W-75 FOR PRV COMPARISONS & SIZING.
 2. ALL GATE VALVES TO BE SAUC, AS CONCERNING PPL.
 3. PLAN REVIEW REQUIRED ON ALL APPLICATIONS.
 4. PRV VALVES MUST BE TESTED.
 5. 2" PPE AND SHALL NOT BE BRASS (NO GALVANIZED FITTINGS ARE ALLOWED).

GENERAL NOTES:

1. VAULT SHALL BE DESIGNED FOR HS20 LOADING.
2. VAULT PENETRATIONS SHALL BE SEALED WITH LINK-SEAL AND NON-SHRINK GROUT (TYP).
3. ALL PRV'S TO BE PRESSURE REDUCING/PRESSURE SUSTAINING, CLA-VAL.
4. ALL WORK TO CONFORM TO TOWN STANDARD SPECIFICATIONS.
5. RESTRAINED JOINT SECTIONS OF PIPE SHALL BE MEG-A-LUGGED.
6. ALL GATE VALVES LOCATED IN THE VAULT SHALL HAVE RISING STEM WHEEL OPERATORS.
7. ALL PIPING SHALL BE DUCTILE IRON PRESSURE CLASS 350.
8. PRESSURE GAUGES SHALL BE 4" DIAL NON-YELLOWING GLYCERIN FILLED, WITH SNUBBER. MUST HAVE ISOLATION VALVE. PRESSURE RANGES FROM 0 - 200 PSI-UPSTREAM & 0 - 200 PSI-4" DOWNSTREAM.
9. MANUFACTURERS REPRESENTATIVE SHALL CERTIFY THE INSTALLATION OF PRV'S AND SETTINGS.
10. FABRICATED OR PRECAST CONCRETE VAULT DESIGN SHALL BE REVIEWED BY THE TOWN.
11. THE FOLLOWING ARE STANDARD SETTINGS. THEY MUST BE CONFIRMED WITH THE TOWN FOR EACH VAULT.
12. ALL BURIED PIPE AND FITTINGS SHALL BE WRAPPED WITH 8 MIL POLYETHYLENE.
13. SHOP DRAWINGS TO BE SUBMITTED AT TIME OF PROJECT PLAN APPROVAL.
14. ALL PRV VAULTS MUST BE VENTED.

PRPSV DESIGN PARAMETERS & SETTINGS
TABLE W-7b1

MAIN DIAMETER (D")	DESIGN FLOW (Q 10 fps)	PRESSURE REDUCING - PRESSURE SUSTAINING VALVE / CONNECTING PIPE SIZES				VAULT SIZES
		PRV #1/D1	PRV #2/D2	PRV #3/D3	PRV #4/D4*	
8	1600	6" / 6"	NA	2" / 2"	NA	10' x 10'
12	3200	6" / 6"	6" / 6"	2" / 2"	NA	10' x 10'
16	6200	8" / 8"	8" / 8"	4" / 4"	2" / 2"	12' x 12'
18	8000	8" / 8"	8" / 8"	4" / 4"	2" / 2"	12' x 12'
20	10000	8" / 8"	12" / 12"	4" / 4"	2" / 2"	12' x 12'
24	14000	12" / 12"	12" / 12"	4" / 4"	2" / 2"	12' x 12'

NOTE:

PRV #4 WILL ONLY BE INSTALLED WHEN THE DOWNSTREAM SYSTEM IS NOT SUPPLIED BY A RESERVOIR. IF 12" OR LARGER PRV'S ARE INSTALLED INSIDE VAULT, LIFTING HOIST & ROTATING BOOM SHALL BE INSTALLED.

TABLE W-7b2

DOWNSTREAM PRESSURE ZONE	MAXIMUM HGL	PRESSURE REDUCING - PRESSURE SUSTAINING VALVE SETTINGS (HYDRAULIC GRADE LINE, FEET)				
		DOWNSTREAM HGL				UPSTREAM HGL
		PRV #1 HGL	PRV #2 HGL	PRV #3 HGL	PRV #4 HGL	ALL PRV'S
RED	6680	6660	6640	6670	6680	6745
PURPLE	6591	6571	6551	6581	6591	6605
BLUE	6520	6500	6480	6510	6520	6516
YELLOW	6349	6329	6309	6339	6349	6445
ORANGE	6192	6172	6152	6182	6192	6274

NOTE:

REDUCED PRESSURE SETTING (psi) = PRV # - DOWNSTREAM HGL - GROUND ELEV @ VAULT / 2.31.
SUSTAINED PRESSURE SETTING (psi) = (UPSTREAM SUSTAINED HGL - GROUND ELEV. AT VAULT) / 2.31.

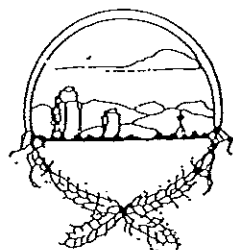

PRESSURE REDUCING VALVE VAULT

Town of Bennett

Issued: _____

Revised: _____

Drawing No.
W-12a

NOTE:

1. PLUG SHALL BE MECHANICALLY RESTRAINED:
 - A. FOR SLEEVE TYPE MACHINED COUPLING PIPE OR PIPE WITHOUT BELL, ROD BACK TO THE NEXT COUPLING UPSTREAM.
 - B. FOR BELL & SPIGOT PIPE, TIE TO BELL (SHOWN).
2. BLOW OFF ASSEMBLY SHALL BE INSTALLED AT TEMPORARY DEAD ENDS ONLY.

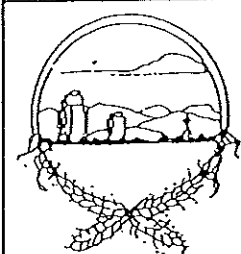
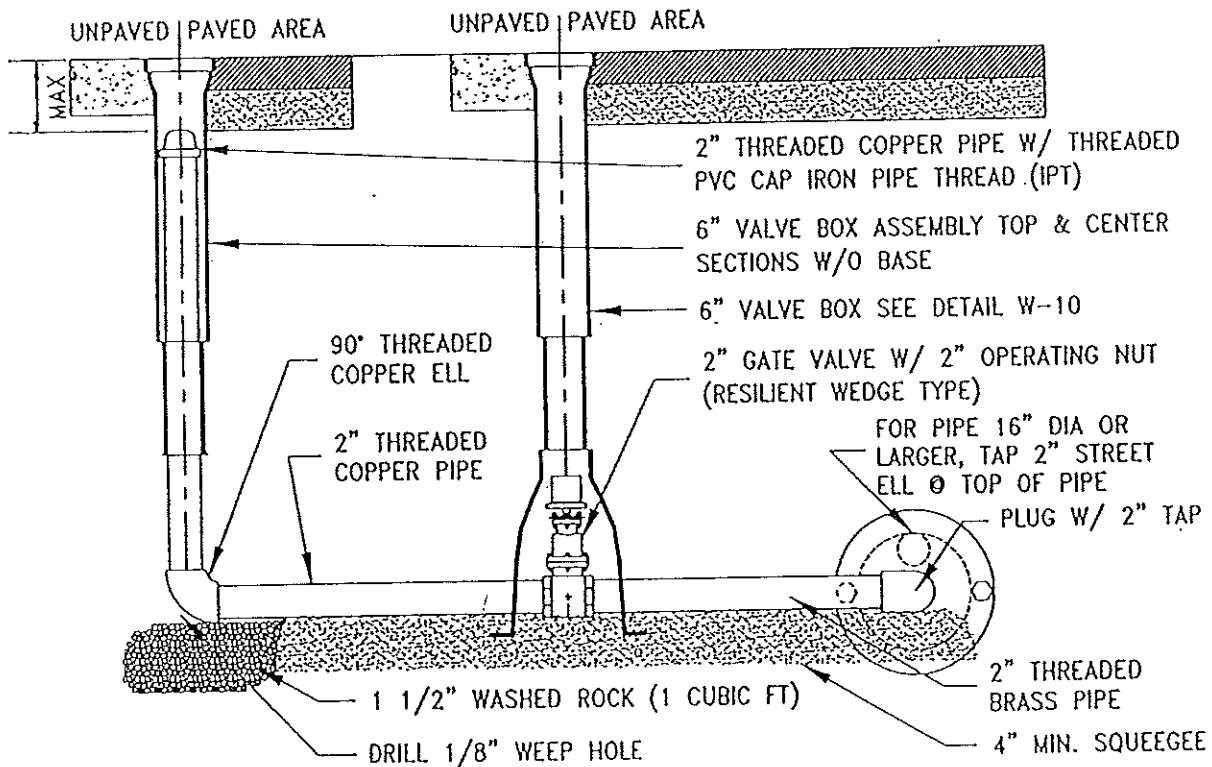
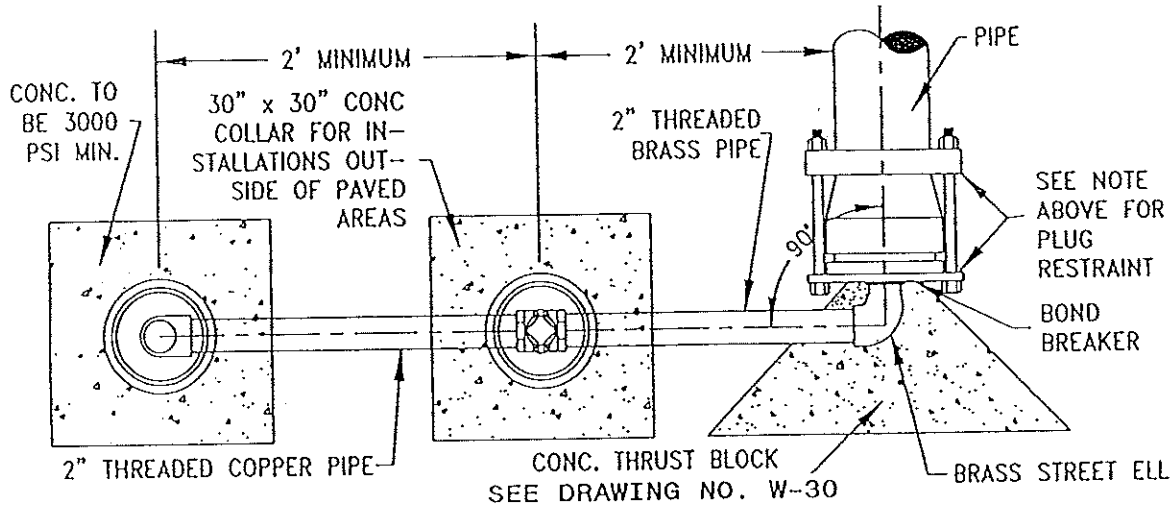

TEMPORARY BLOW-OFF ASSEMBLY

Town of Bennett

Issued: _____

Revised: _____

Drawing No.
W-13

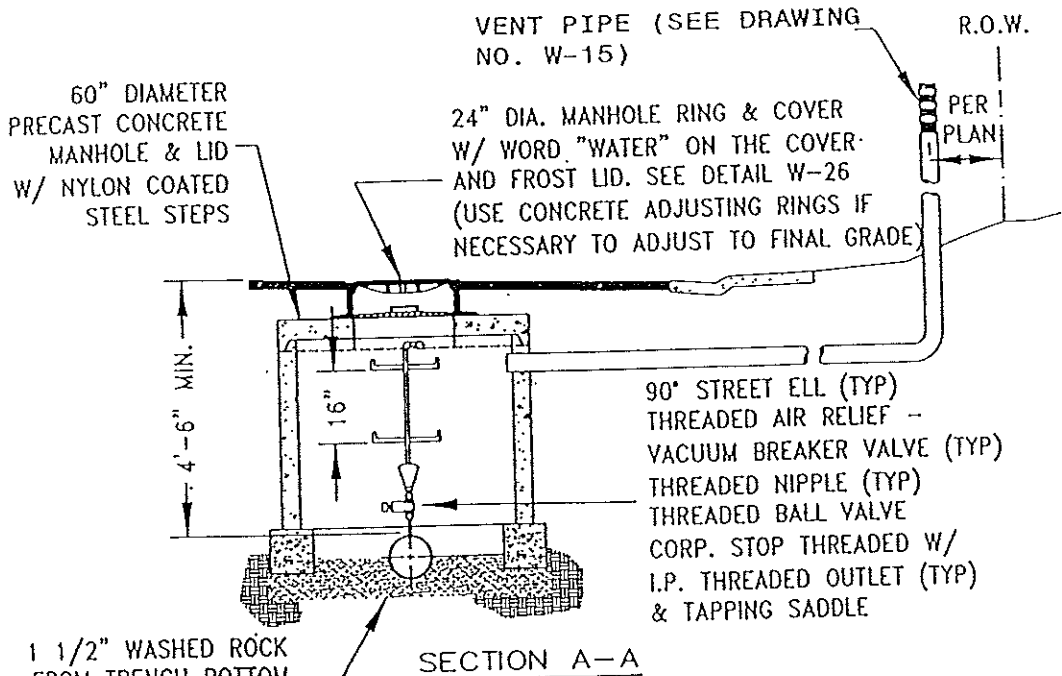

1 1/2" WASHED ROCK FROM TRENCH BOTTOM TO 3" BELOW TOP OF PIPE (6" MIN)

SECTION A-A

CONC M.H. FOOTINGS 8' x 1' x 1' REINFORCED W/ 2 - #4 REBAR @ 6" O.C., 3" CLEARANCE REQUIRED. FOOTINGS SHALL BE SET ON 3" DEPTH OF 1 1/2" WASHED ROCK.

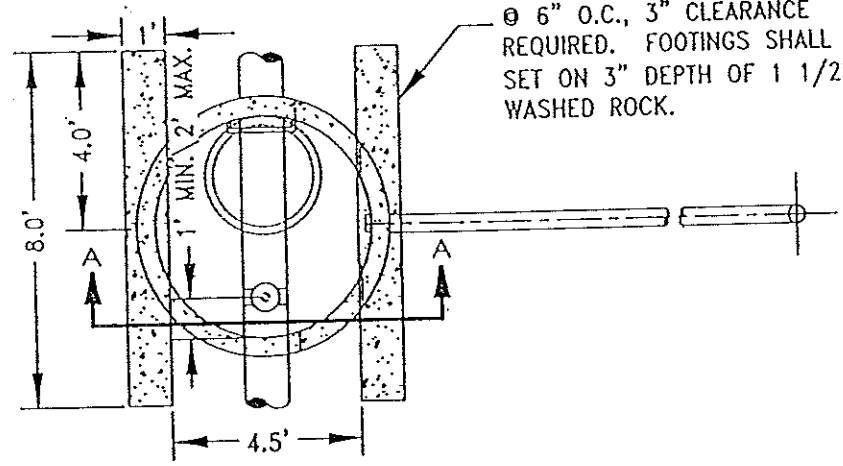

PLAN VIEW

NOTES:

1. AIR RELEASE VALVE SHALL BE PLACED @ THE HIGH POINT OF THE MAIN WATER LINE OR AS DETERMINED THROUGH PLAN REVIEW.
2. APCO 100-C SERIES AIR RELIEF/VACUUM BREAKER VALVES SHALL BE USED. SIZING TO BE ESTABLISHED FROM THE MANUFACTURERS SIZING TABLES & APPROVED BY THE TOWN.

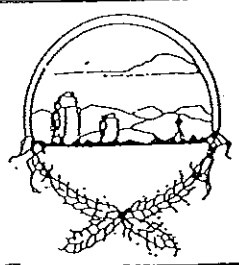

AIR RELEASE VALVE AND VAULT

Town of Bennett

Issued: _____

Revised: _____

Drawing No. W-14

NOTE: VENT PIPES TO BE LOCATED IN THE FIELD @ THE NEAREST INTERSECTION OF THE STREET PROPERTY LINE & SIDE LOT LINE. PAINT PIPE SAFETY YELLOW & LOCATE MANHOLE W/ DISTANCE & DIRECTIONS SIMILAR TO MARKER POST.

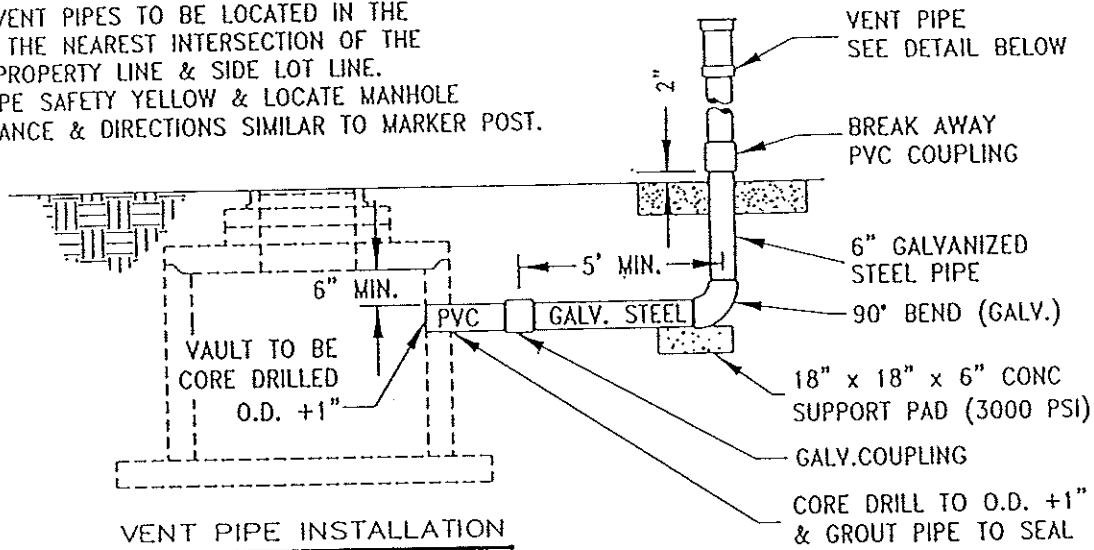

VENT PIPE INSTALLATION

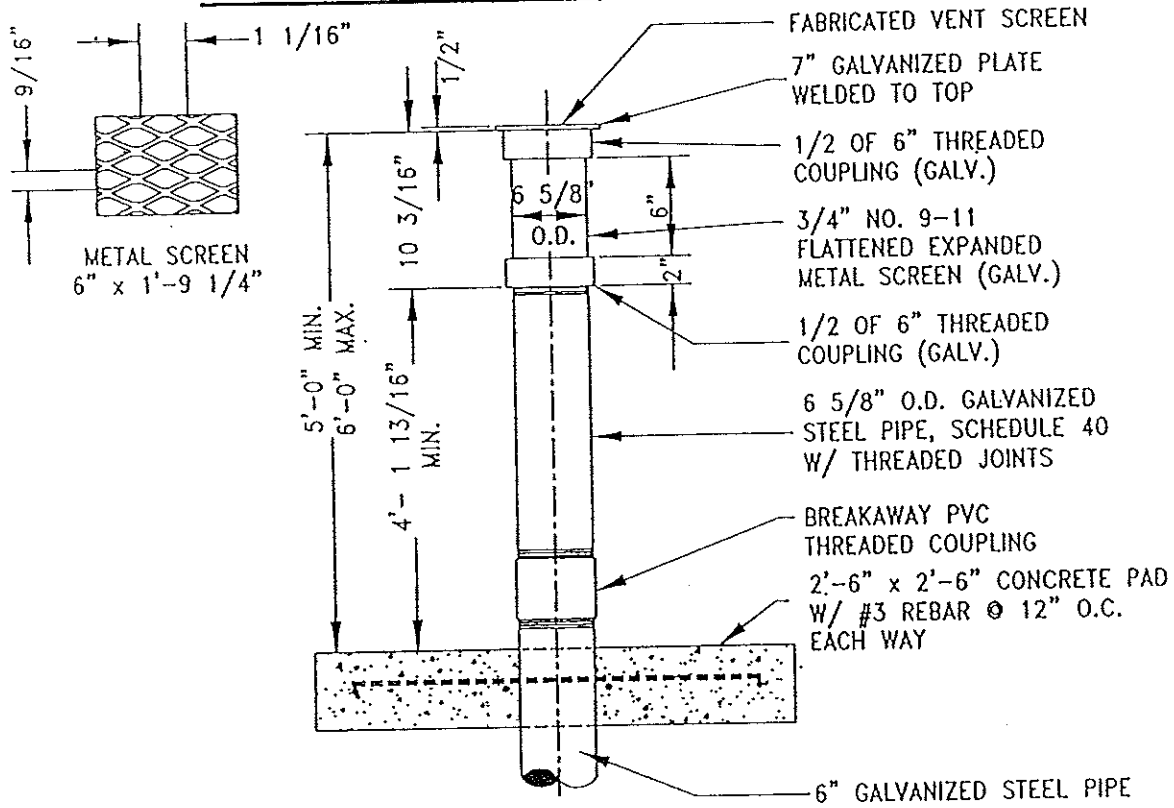

VENT PIPE & BREAK-AWAY COUPLING DETAILS

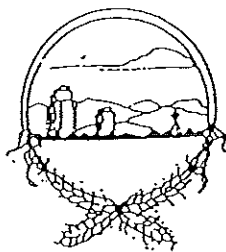

VENT PIPE

Town of Bennett

Issued: _____

Revised: _____

Drawing No.

W-15

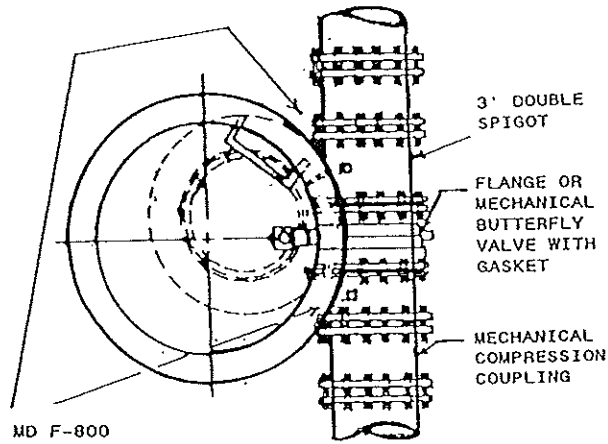

- 1 1/2" FORD STYLE MD F-800
- 1 1/2" COPPER TUBING TYPE K
- 1 1/2" COUPLING-MUELLER H16425
- 1 1/2" THD'D GATE VALVE HAMMOND 125-BRASS
(ONE ON EACH SIDE OF VALVE)

TOP VIEW

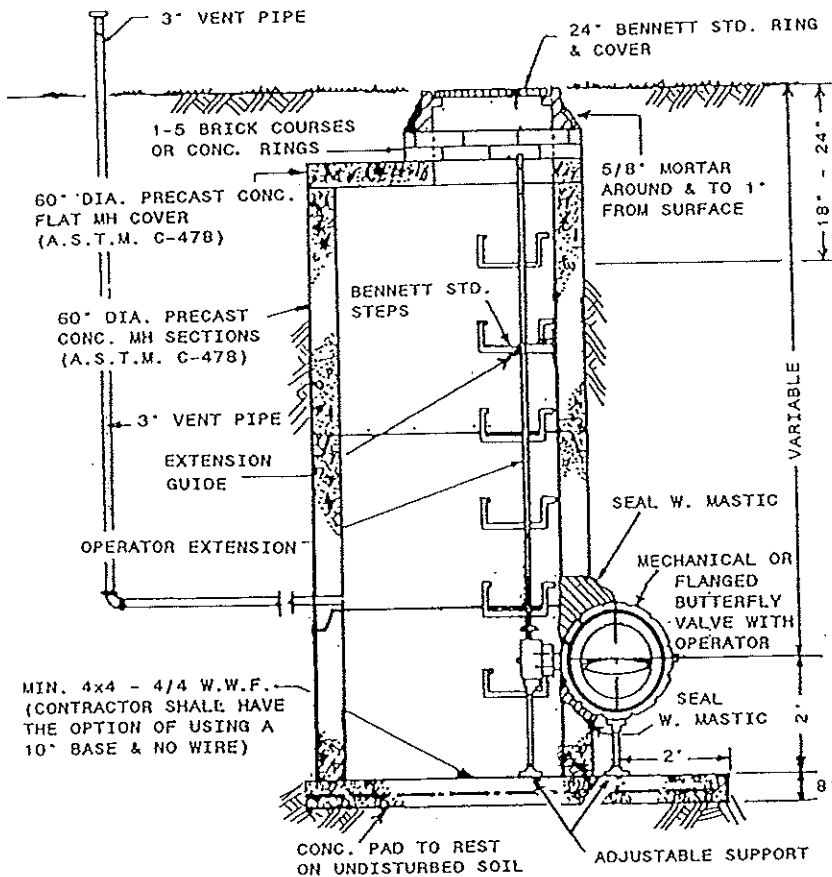

ELEVATION

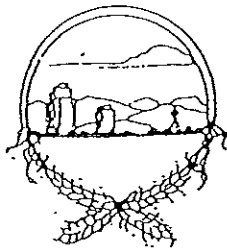

BUTTERFLY VALVE INSTALLATION

Town of Bennett

Issued: _____

Revised: _____

Drawing No.

W-16

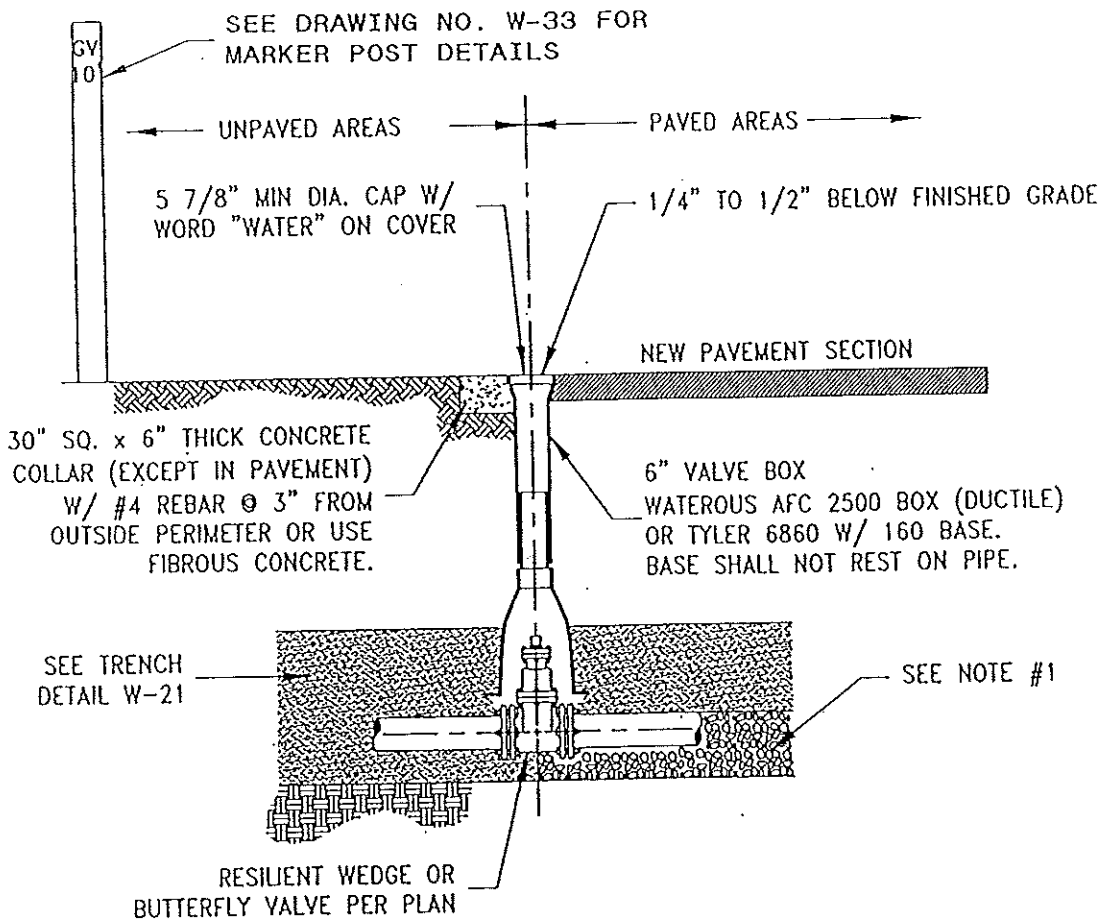

NOTES:

1. CARE SHALL BE TAKEN WHEN INSTALLING VALVES TO ASSURE PROPER SUPPORT OF THE VALVE. THE ENGINEER MAY REQUIRE 3/4" CRUSHED ROCK TO BE INSTALLED UNDER THE VALVE TO PROVIDE PROPER SUPPORT.
2. VALVES SHALL NOT BE PLACED IN CONCRETE CROSS PANS, GUTTERS, OR OTHER DRAINAGE WAYS.
3. OPERATING NUTS OR EXTENSIONS SHALL NOT BE SET CLOSER THAN THREE (3) FEET FROM FINISHED GRADE: IF OPERATING NUT IS DEEPER THAN FIVE (5) FEET FROM FINAL GRADE, PROVIDE A 1 1/4" EXTENSION SHAFT W/ CENTERING RING. OPERATOR EXTENSIONS SHALL BE CONNECTED TO THE VALVE OPERATOR NUT USING A SET SCREW.
4. GATE VALVE SHALL BE POLYETHYLENE WRAPPED (8 MIL).
5. CONCRETE COLLARS & MARKER POSTS ARE REQUIRED WHEN VALVE IS LOCATED IN AN UNPAVED AREA.
6. VALVE BOXES ARE TO BE BROUGHT UP TO GRADE @ THE TIME OF PAVEMENT PLACEMENT OR OVERLAY. VALVE BOX ADJUSTING RINGS ARE NOT ALLOWED.
7. SEE DRAWING NO'S W-22 & 23 FOR TYPICAL VALVE LOCATIONS

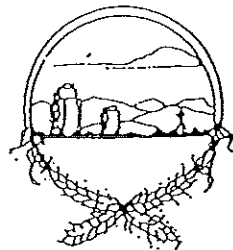

TYPICAL VALVE BOX

Town of Bennett

Issued: _____

Revised: _____

Drawing No.

W-17

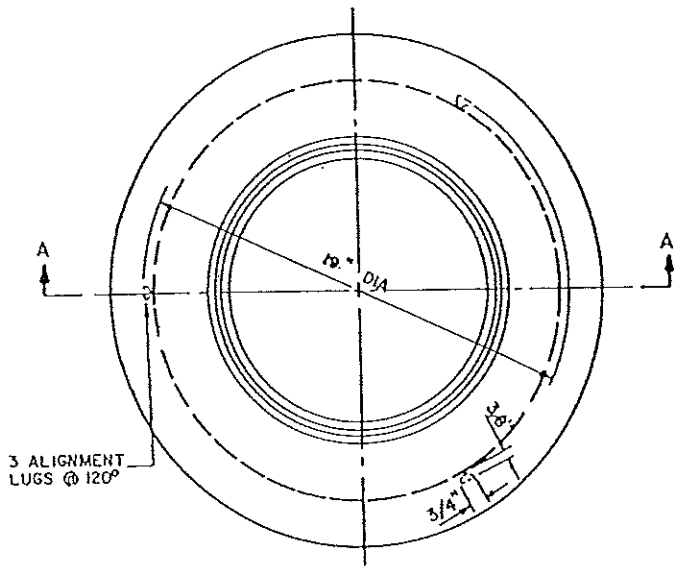

PIT COVER

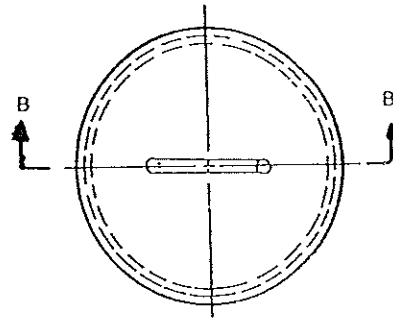

FROST COVER

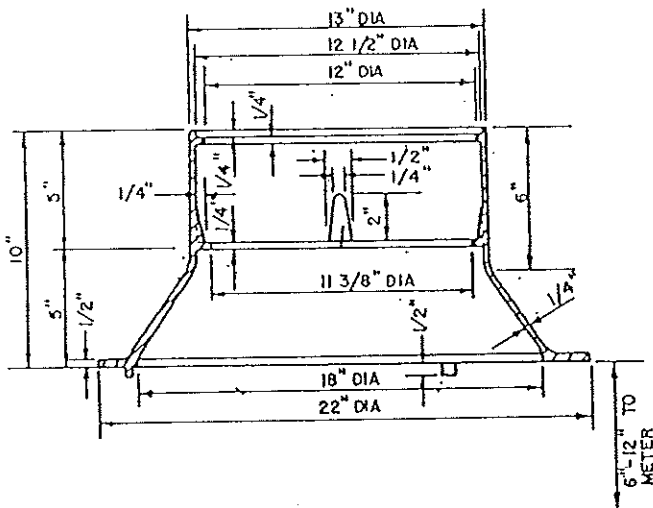

SECTION A-A

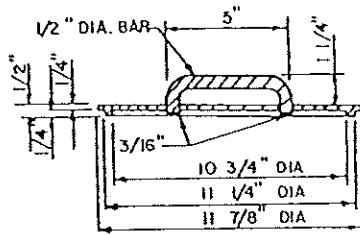

SECTION B-B

NOTES

1. THE LID SHALL BE CAST IRON
2. THE HOOD MAY BE CAST IRON OR ALUMINUM

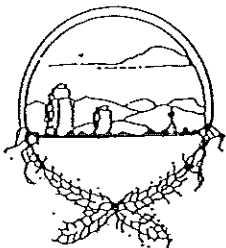

METER PIT COVER

Town of Bennett

Issued: _____

Revised: _____

Drawing No.

W-18

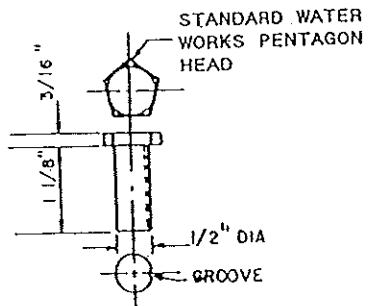

BOLT DETAIL

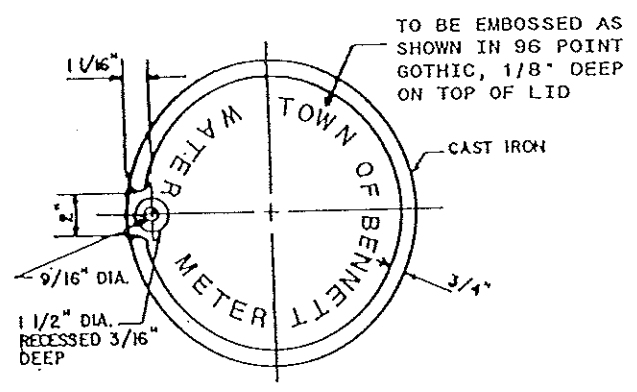

LID TOP VIEW

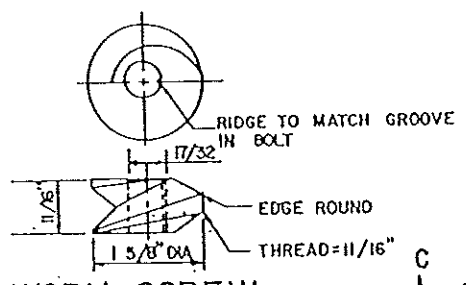

WORM SCREW DETAIL

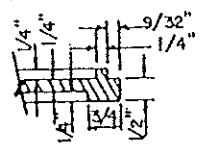

SECTION D-D

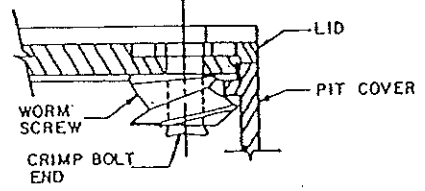

ASSEMBLY DETAIL

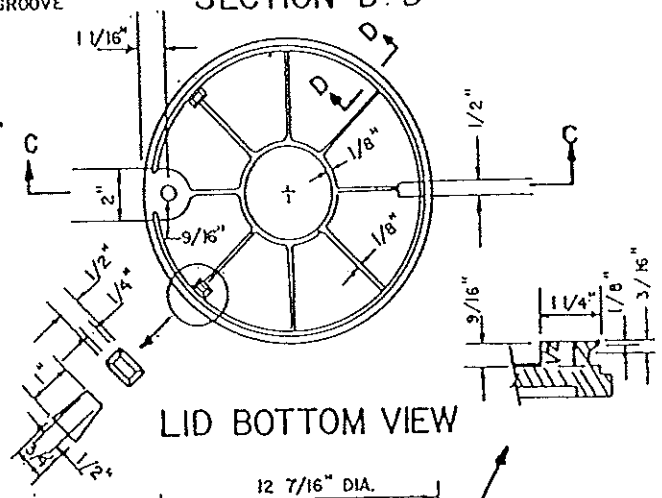

LID BOTTOM VIEW

NOTES

1 THE LID SHALL BE CAST IRON.

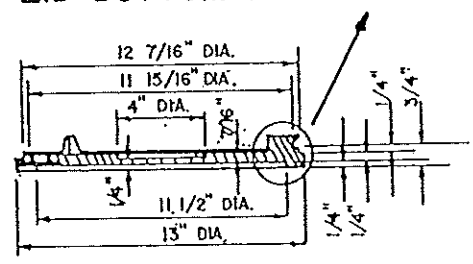

SECTION C-C

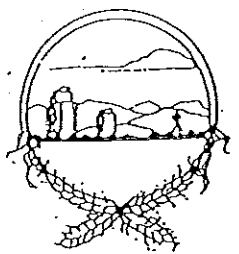

METER PIT COVER

Town of Bennett

Issued: _____

Revised: _____

Drawing No. _____

W-19

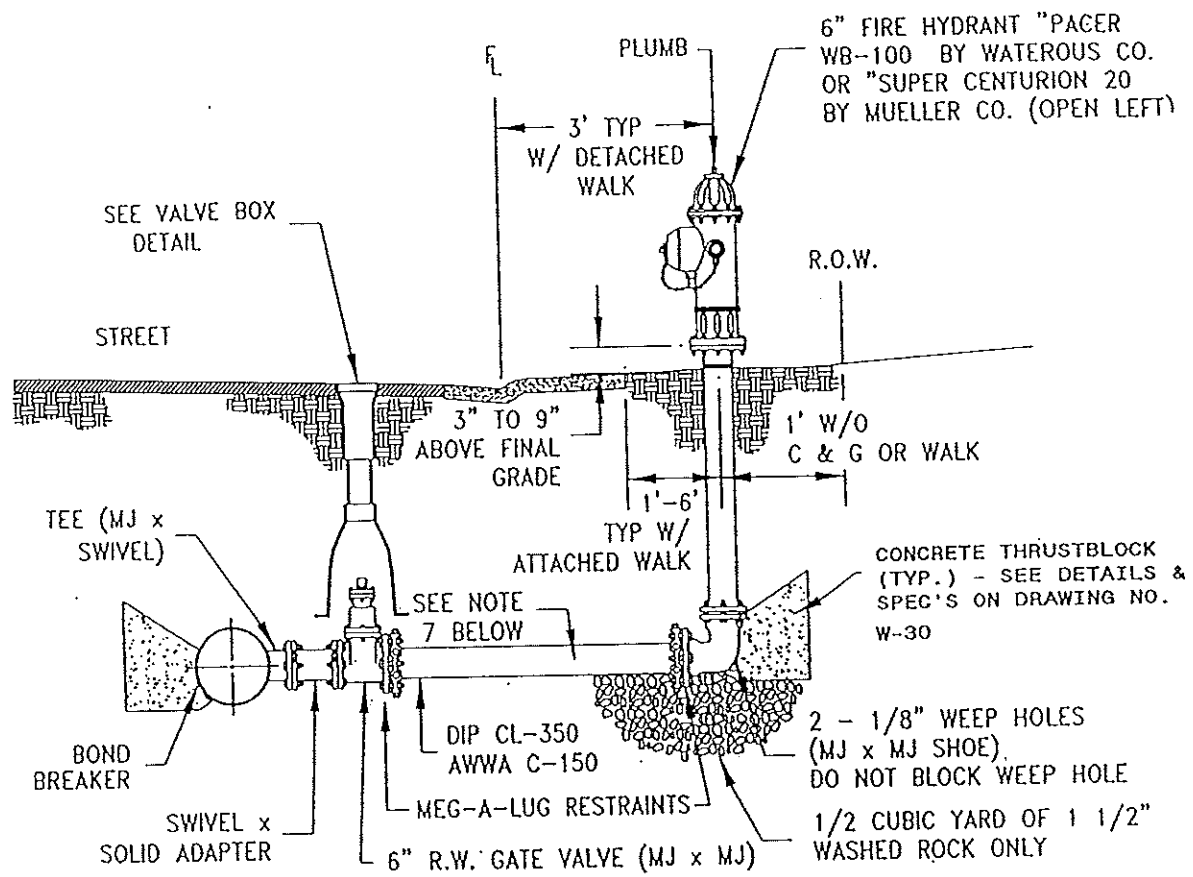

- NOTES:
1. ALL HYDRANTS SHALL BE PAINTED "SAFETY YELLOW" FROM FACTORY. FIELD RE-PAINING, MAY BE REQUIRED BY THE PUBLIC WORKS INSPECTOR.
 2. THE CONNECTIONS SHALL BE 2 - 2 1/2" NOZZLES & 1 - 5 1/4" PUMPER NOZZLE, ALL THREADS TO BE NATIONAL STANDARD W/ 1 1/2" PENTAGONAL CAP NUTS. ALL HYDRANTS SHALL BE AWWA C-502-94 STANDARD OPEN LEFT.
 3. NO TAPS SHALL BE ALLOWED BETWEEN THE HYDRANT & THE VALVE.
 4. THE ENTIRE FIRE HYDRANT ASSEMBLY SHALL BE WRAPPED W/ 8 MIL POLYETHYLENE, INCLUDING THE RISER PORTION, TO FINISHED GRADE. CUT HOLE IN WRAP AT WEEP HOLE.
 5. ALL FIRE HYDRANTS SHALL BE INSTALLED PLUMB & LOCATED ACCORDING TO PROJECT PLANS.
 6. SEE FIRE HYDRANT LOCATION ON DRAWING NO'S W-22 & 23 FOR PROPER LOCATION RELATIVE TO OTHER IMPROVEMENTS & REFER TO APPROVED PLANS.
 7. THE MECHANICAL JOINTS OF THE FIRE HYDRANT ASSEMBLY SHALL BE RESTRAINED VIA ALL-THREAD RODDING & CLAMPS OR MEG-A-LUG JOINT CLAMPS UNLESS MORE THAN ONE SECTION OF PIPE IS USED BETWEEN THE HYDRANT & THE VALVE. IF MORE THAN ONE SECTION IS USED, MEG-A-LUG (OR APPROVED EQUAL) RESTRAINTS SHALL BE USED AT ALL CONNECTIONS. (SEE DETAIL BELOW).

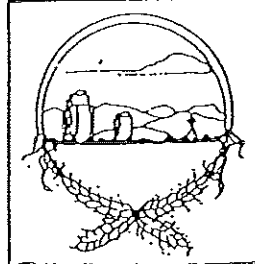
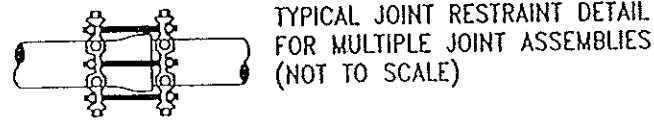

FIRE HYDRANT ASSEMBLY

Town of Bennett

Issued: _____

Revised: _____

Drawing No.
W-20

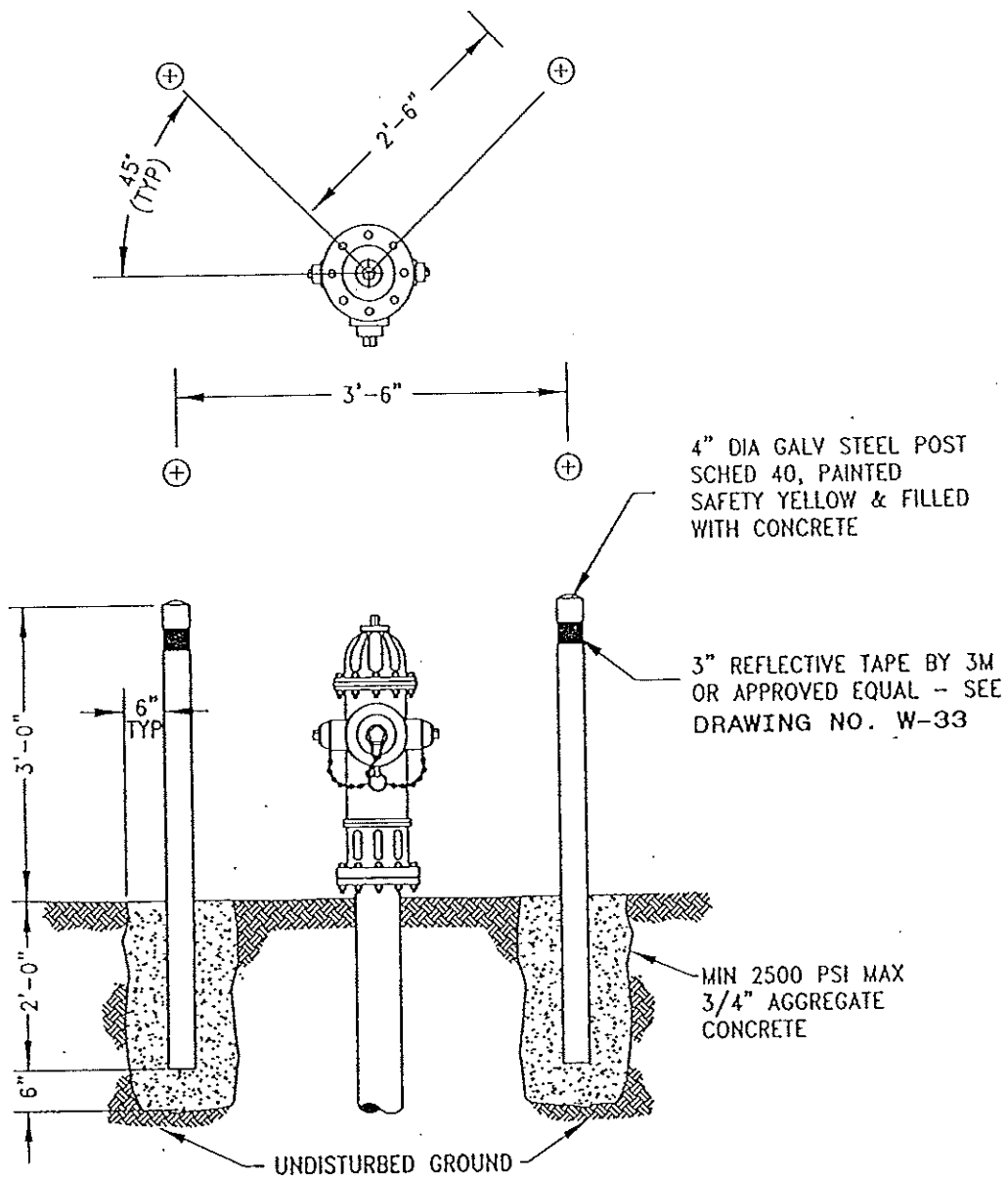

NOTES:

1. TO BE USED IN AREAS WHERE HYDRANTS ARE EXPOSED TO VEHICULAR TRAFFIC.
2. STEAMER CONNECTION ON FIRE HYDRANT SHALL BE DIRECTED AS NOTED ON PLANS.

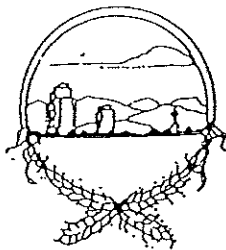

FIRE HYDRANT BOLLARDS

Town of Bennett

Issued: _____

Revised: _____

Drawing No.
W-21

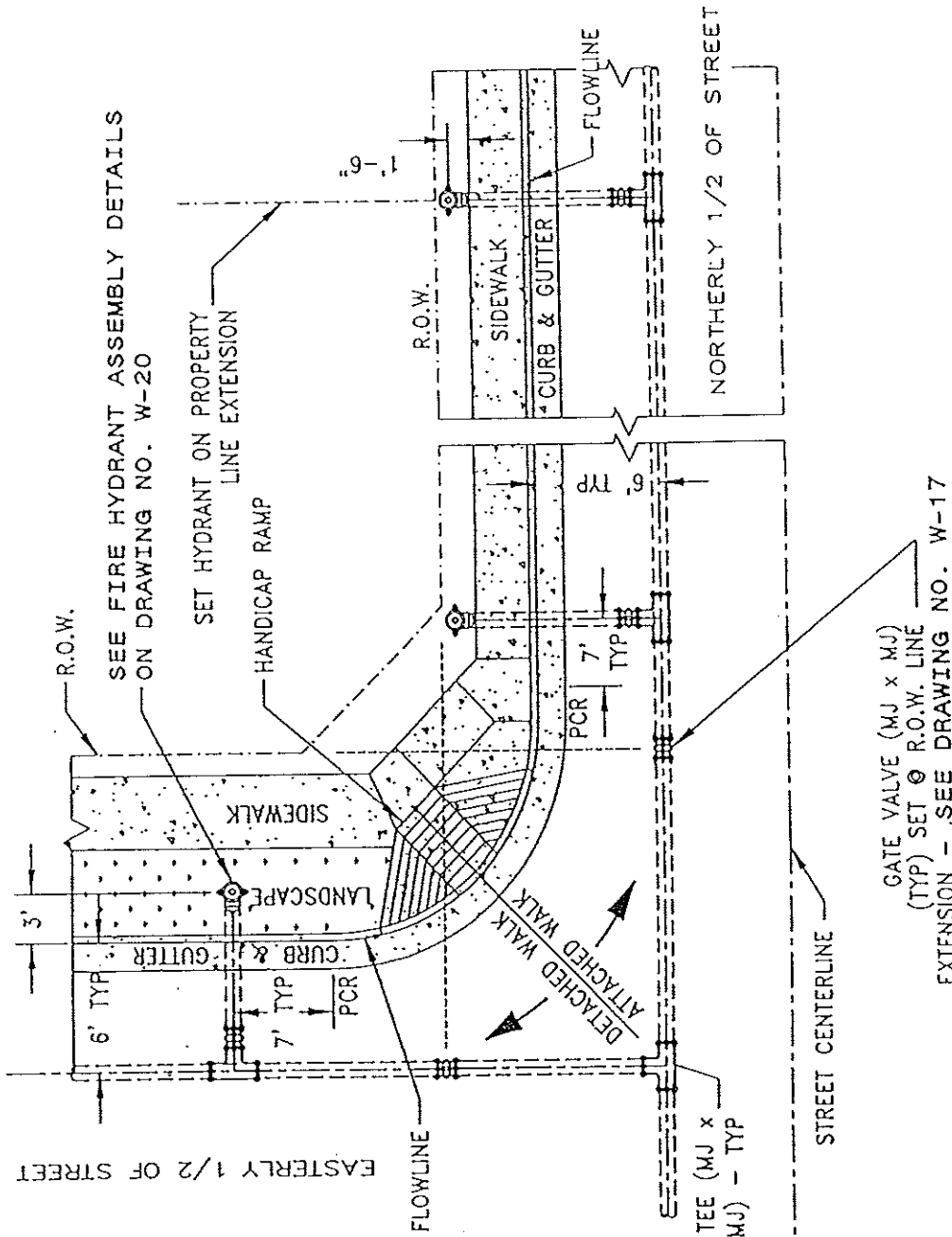

NOTE:
 1. VALVES SHALL NOT BE PLACED IN CONCRETE CROSS PANS OR WITHIN GUTTER PORTIONS

GATE VALVE (MJ x MJ)
 (TYP) SET @ R.O.W. LINE
 EXTENSION - SEE DRAWING NO. W-17

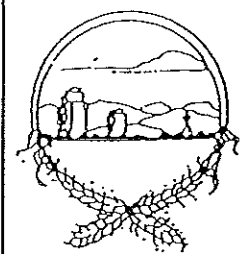
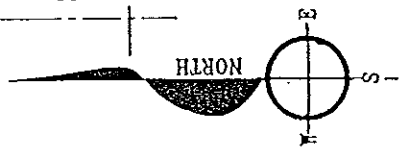

VALVE & HYDRANT LOCATIONS

Town of Bennett

Issued: _____

Revised: _____

Drawing No.

W-22

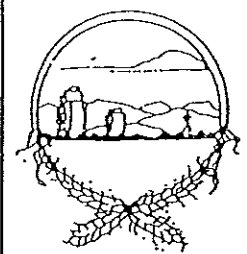
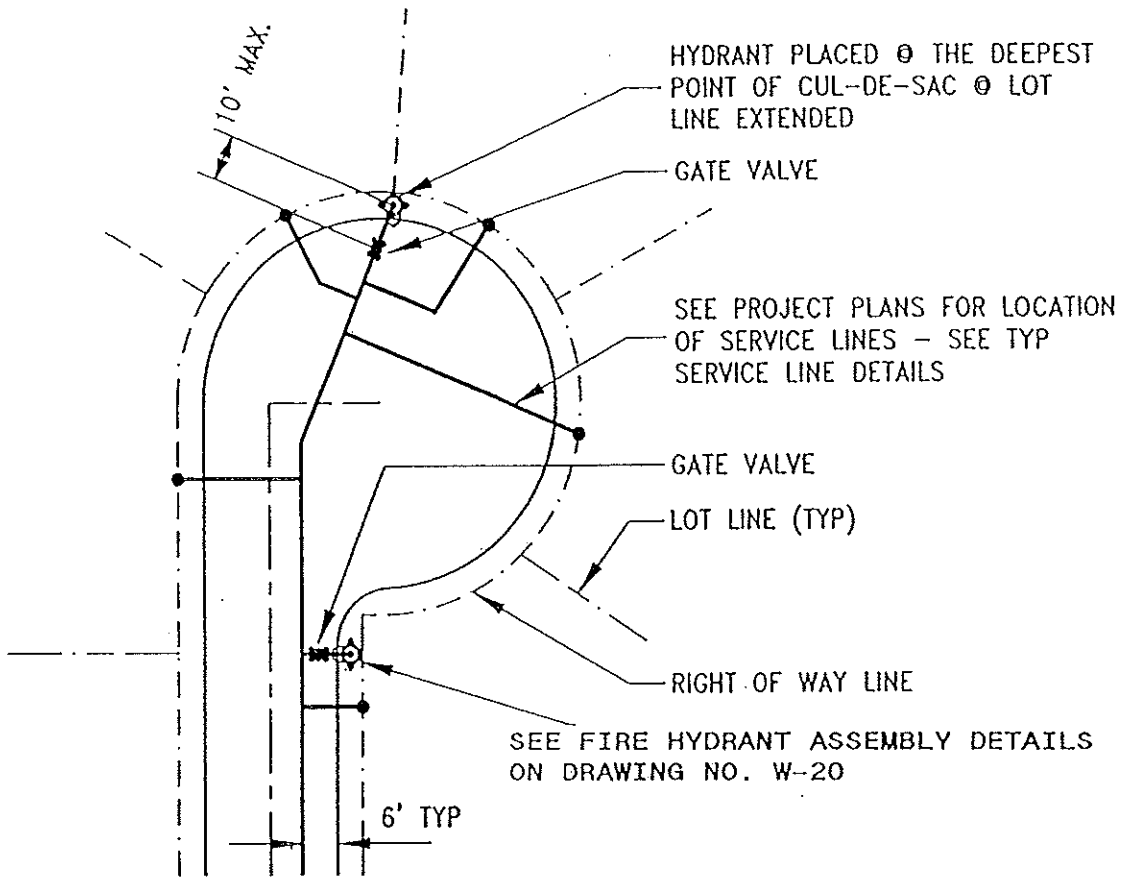

WATER SYSTEM
IN CUL-DE-SACS

Town of Bennett

Issued: _____

Revised: _____

Drawing No.

W-23

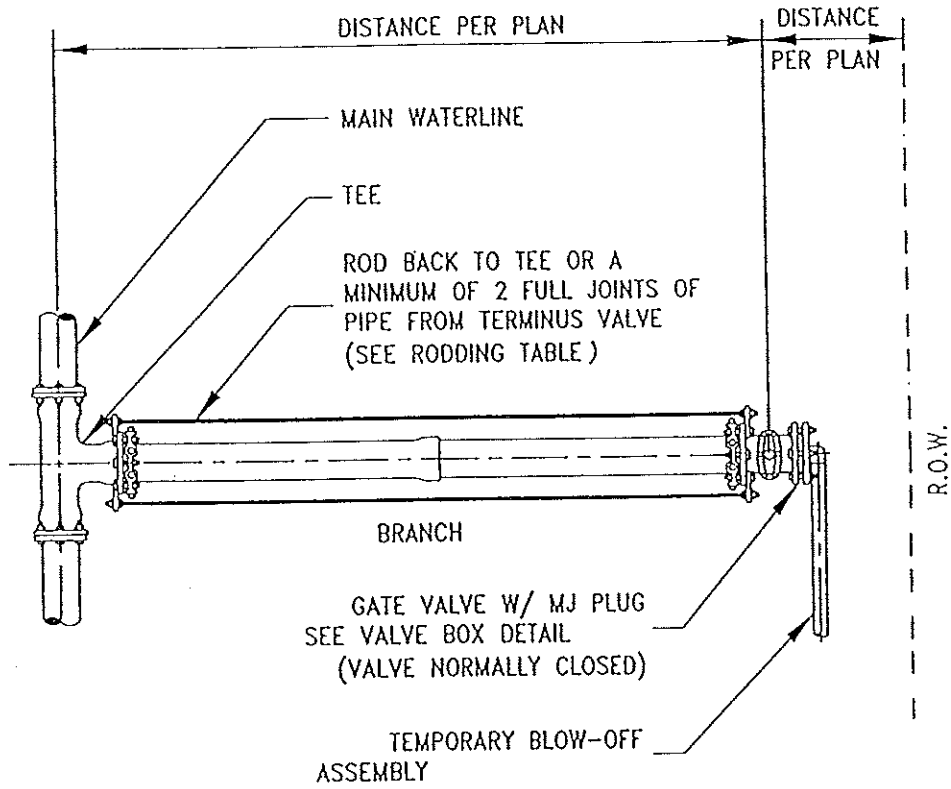

NOTES:

1. ALL FITTINGS SHALL BE MJ W/ MEG-A-LUG.
2. LOCATION OF STUB OUT SHALL BE PER PLAN.
3. STUB OUT SHALL BE PRESSURE TESTED & CLEAR WATER TESTED @ TIME OF MAIN LINE TESTING. VALVE SHALL BE CLOSED AFTER TESTS.

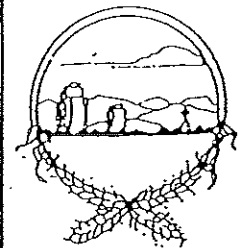

STUB OUT CONFIGURATION

Town of Bennett

Issued: _____

Revised: _____

Drawing No.

W-24

NOTES:

1. WHERE WATER LINE COVER EXCEEDS 7'-6" AT THE LOW POINT OF THE CONDUIT CROSSING, VERTICAL BENDS ARE REQUIRED. WHEN COVER IS LESS THAN 7'-6", PIPE JOINTS MAY BE DEFLECTED 1/2 THE MANUFACTURER'S RECOMMENDED DEFLECTION IN LIEU OF VERTICAL BENDS. THE LIMITS OF THE DEPRESSED AREA SHALL BE DOCUMENTED ON THE "AS-BUILT" DRAWINGS.
2. IF UTILITY CROSSING IS SANITARY SEWER & IS OVER A RAW OR POTABLE WATER LINE, ALL UTILITY CROSSING JOINTS WITHIN 10' SHALL BE ENCASED 1' BOTH SIDES OF THE JOINT W/ CONCRETE. SEE ENCASUREMENT DETAIL ON DRAWING NO. W-28
3. MULTIPLE JOINTS BETWEEN MEG-A-LUG FITTINGS SHALL BE RESTRAINED.
4. RODDING MAY BE SUBSTITUTED FOR MEG-A-LUG RESTRAINT. SEE RODDING TABLE ON DRAWING NO. W-26

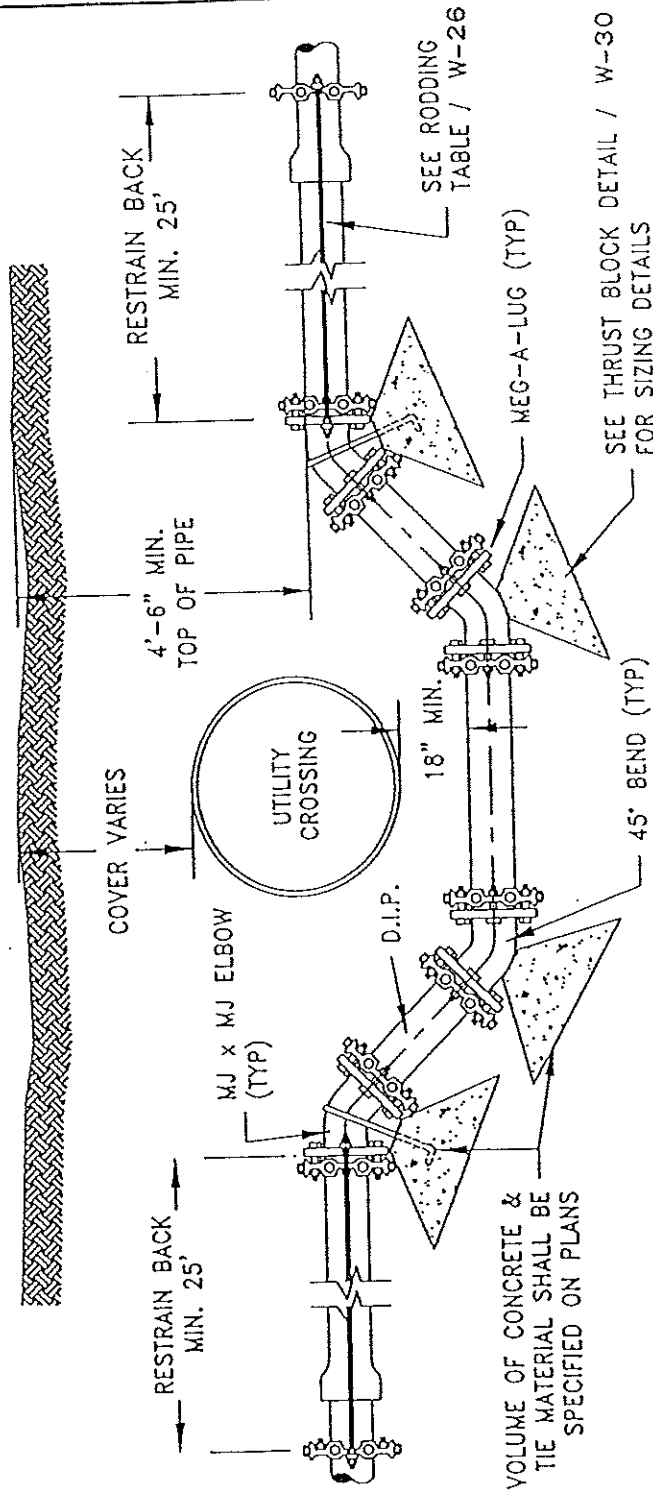

VOLUME OF CONCRETE & TIE MATERIAL SHALL BE SPECIFIED ON PLANS

SEE RODDING TABLE / W-26

SEE THRUST BLOCK DETAIL / W-30 FOR SIZING DETAILS

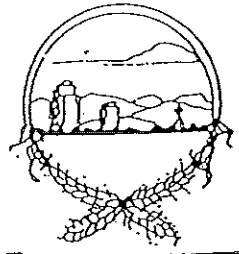

UTILITY CROSSING
Town of Bennett

Issued: _____

Revised: _____

Drawing No.

W-25

ROD DIAMETER, GRADE & LENGTH OF RESTRAINED PIPE

PIPE SIZE	4"	6"	8"	12"	16"	20"	24"
FITTING	L	L	L	L	L	L	L
90° BEND, TEE, PLUG OR VALVE	30'	45'	60'	86'	108'	132'	155'
45° BEND	M1	13'	18'	25'	32'	39'	45'
22 1/2° BEND	M1	M1	M1	M1	M1	M1	M1
11 1/4° BEND	--	--	M1	M1	M1	M1	M1
					D	L	G

LEGEND
 D = DIAMETER
 L = LENGTH
 G = GRADE
 M1 = MINIMUM OF 1 FULL LENGTH OF PIPE

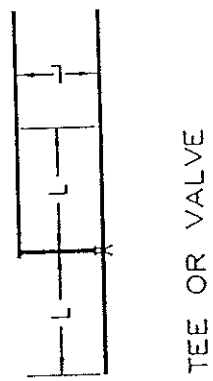
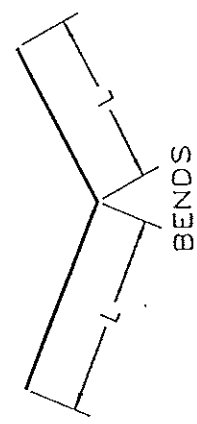
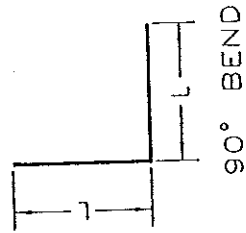

- NOTES:
1. LENGTH OF RESTRAINED PIPE MEASURED EACH WAY FROM VALVES & BENDS.
 2. MINIMUM 5' GROUND COVER REQUIRED.
 3. ALL FITTINGS SHALL BE MEG-4-LUGGED.

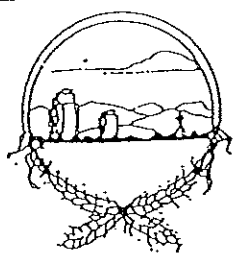

PIPE RESTRAINT TABLE

Town of Bennett

Issued: _____

Revised: _____

Drawing No.
 W-26

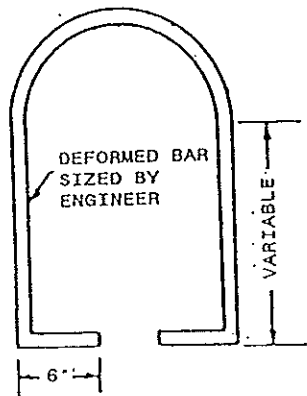
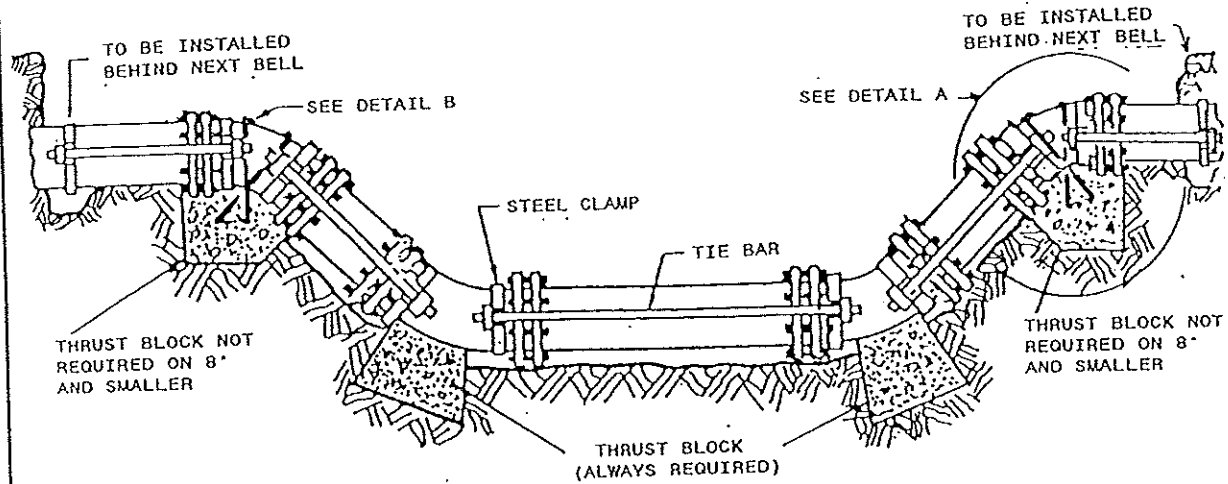

DETAIL B

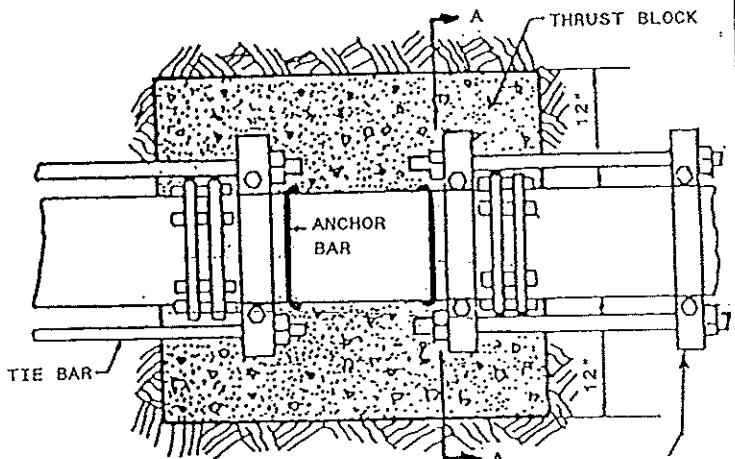

PLAN VIEW A

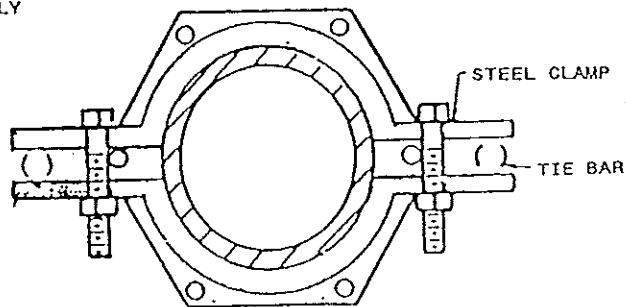

SECTION A-A

NOTES

1. CLAMPS SHALL BE USED FOR RODDING.
2. ALL PIPES & RODS SHALL BE WRAPPED SEPERATELY IN POLYETHYLENE.
3. 45 FITTINGS SHALL BE USED.
4. ALL MATERIALS & CONSTRUCTION SHALL BE IN ACCORDANCE WITH THE TOWN OF BENNETT STANDARDS AND SPECIFICATIONS FOR WATERLINE CONSTRUCTION.
5. THERE SHALL BE A MINIMUM CLEARANCE OF 12" BETWEEN WATERLINE & ANY NEW CONSTRUCTION.
6. FITTINGS SHALL BE RODDED TO THE NEXT BELL.
7. NO JOINTS SHALL BE ALLOWED BETWEEN THE FITTINGS.
8. NUMBER & SIZE OF RODS TO BE DETERMINED BY THE ENGINEER.

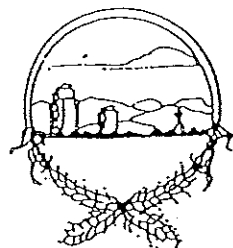

WATERLINE LOWERING DETAIL

Town of Bennett

Issued: _____

Revised: _____

Drawing No. .
W-26a

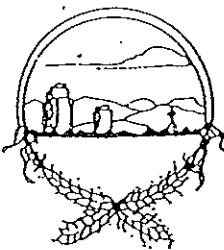

WATERLINE STANDARD DETAIL
PIPE CLAMP

Town of Bennett

Issued: _____

Revised: _____

Drawing No.

W-26b

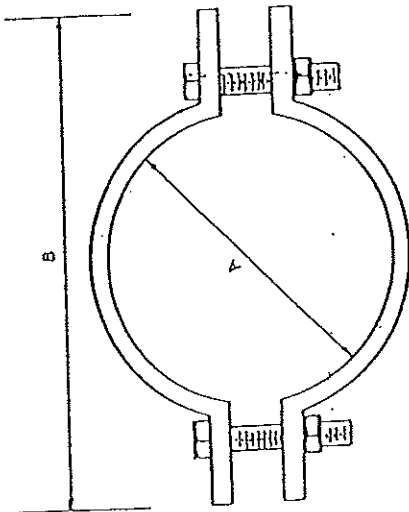

UNDERGROUND CLAMP

MATERIAL: STEEL
 FUNCTION: CLAMP IS USED FOR UNDERGROUND
 A.W.W.A. CAST IRON WATER PIPE TO
 PREVENT JOINTS FROM SEPERATING
 COMPONENTS: TWO HALF CLAMPS & TWO BOLTS
 WITH NUTS - ASSEMBLED

FINISH: PLAIN

PIPE SIZE (IN.)	A	B	BOLT SIZE (IN.)	STOCK SIZE	RECOM. TIE ROD SIZE (IN.)
3	3.94	10-7/8	3/8	3/8 x 2	3/4
4	4.80	12	3/8	1/2 x 2	3/4
6	6.90	14-5/16	3/8	1/2 x 2	3/4
8	9.05	16-7/16	3/8	1/2 x 2	3/4
10	11.10	18-3/16	3/8	1/2 x 2	3/4
12	13.20	21-7/16	3/8	3/4 x 3	1
14	15.30	26-7/16	7/8	3/4 x 4	1-1/8
16	17.40	28-7/8	1	3/4 x 4	1-1/4
18	19.50	31-1/4	1-1/4	3/4 x 4-1/2	1-3/8
20	21.60	36-1/4	1-1/4	3/4 x 6	1-3/8
24	26.80	38-1/4	1-1/2	3/4 x 6	1-1/2

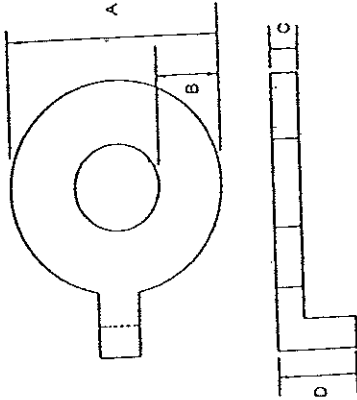

LUG WASHER

MATERIAL: CAST IRON
 FUNCTION: USED WITH UNDERGROUND CLAMP WHEN TIE RODS
 ARE REQUIRED. THE PROJECTING LUG BEARS AGAINST
 THE CLAMP BOLT TO PREVENT WASHER AND TIE ROD
 FROM SLIPPING OFF CLAMP

FINISH: PLAIN

ROD SIZE (IN.)	A	B	C	D
3/4	2 - 3/4	7/8	9/16	1 - 5/8
1	3 - 3/4	1 - 1/4	11/16	3 - 1/4
1-1/4	3 - 3/4	1 - 5/8	11/16	3 - 1/4
1-3/8	3 - 3/4	1 - 1/2	11/16	3 - 1/4
1-1/2	3 - 3/4	1 - 5/8	11/16	3 - 1/4

- NOTES:
- CLAMPS SHALL BE USED FOR ALL HARNESS RODDING.
 - ELCAR- OR APPROVED EQUAL SHALL BE USED.
 - TIE ROD SIZE SHALL BE IN ACCORDANCE WITH THE TABLE, UNLESS SPECIFIED OTHERWISE.

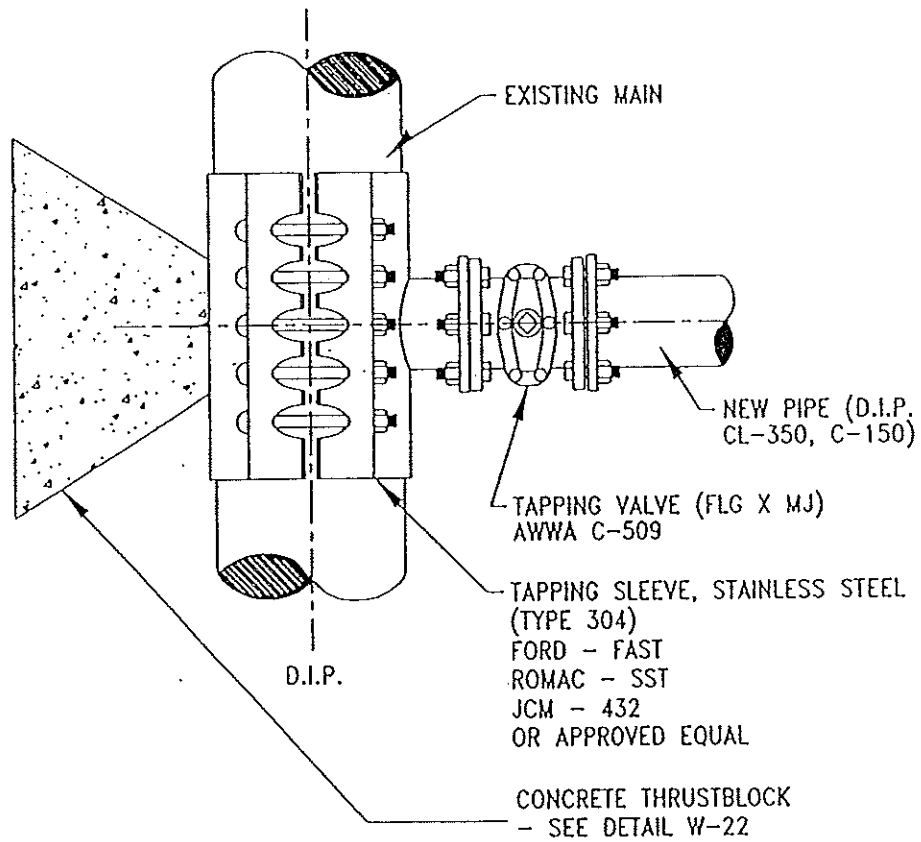

NOTES:

1. THE TOWN SHALL BE NOTIFIED AT LEAST 48 HOURS PRIOR TO TAPPING.
THE TOWN'S REPRESENTATIVE SHALL BE ON SITE DURING TAPPING.
2. WET TAPPING DETAIL IS FOR USE ON DUCTILE IRON PIPE.
3. SIZE x SIZE WET TAP CONNECTIONS WILL NOT BE ALLOWED.

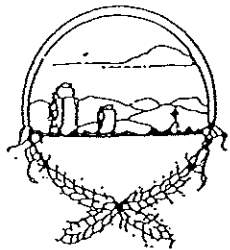

WET TAP CONNECTION

Town of Bennett

Issued: _____

Revised: _____

Drawing No.

W-27

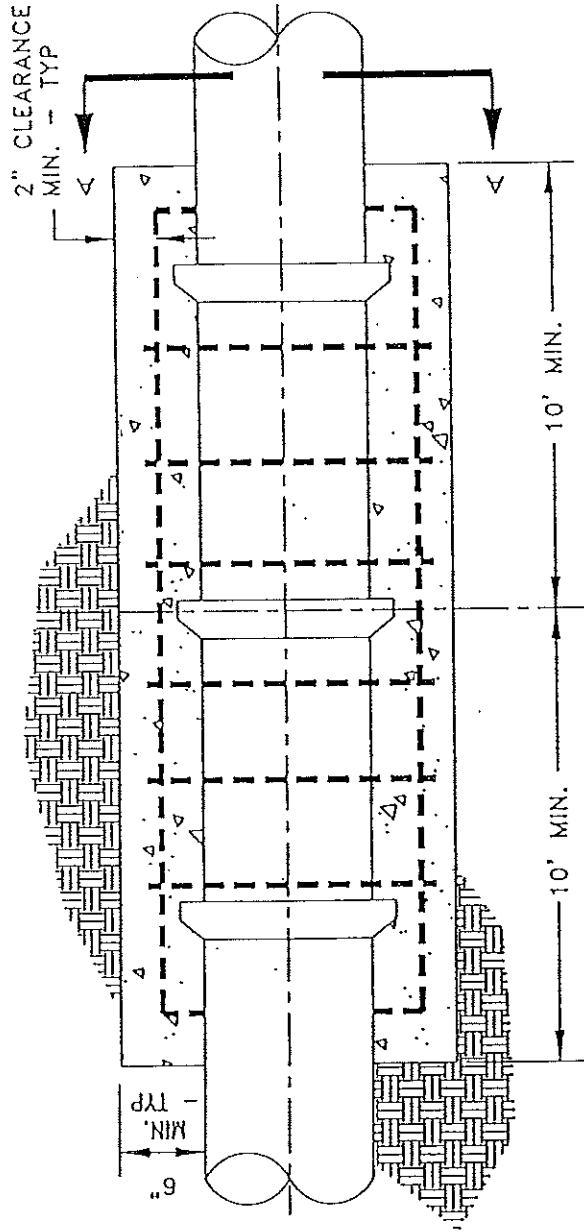

2" CLEARANCE
MIN. - TYP

VARIES - SEE TABLE

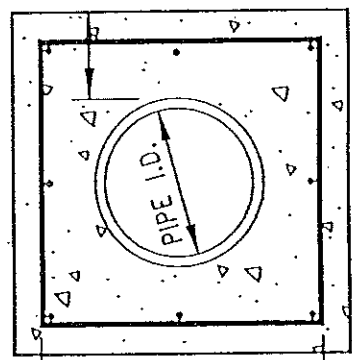

SECTION A - A

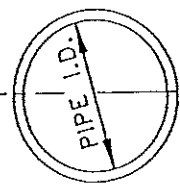

6" MIN. - TYP

NOTES:
CONCRETE ENCASEMENT WILL BE REQUIRED ON SEWER LINE WHEN CLEAR VERTICAL DISTANCE FROM WATER LINE IS LESS THAN 1'-6" OR HORIZONTAL DISTANCE IS LESS THAN 10' BETWEEN PARALLEL LINES.
CONCRETE ENCASEMENT REQUIRED IN ALL CASES WHERE SEWER LINE IS ABOVE WATER LINE OR IS UNDER A WATERWAY CROSSING.

PIPE I.D.	NO. OF LONGITUDINAL BARS & LOCATION				
6" TO 8"	4 - #4 BARS	1 EACH CORNER			
10" TO 18"	8 - #4 BARS	3 EACH SIDE			
21" TO 33"	12 - #4 BARS	4 EACH SIDE			
36"	16 - #4 BARS	5 EACH SIDE			

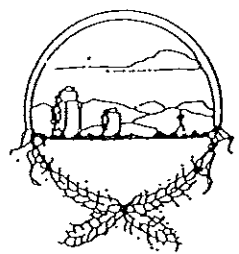

PIPE ENCASEMENT

Town of Bennett

Issued: _____

Revised: _____

Drawing No.

W-28

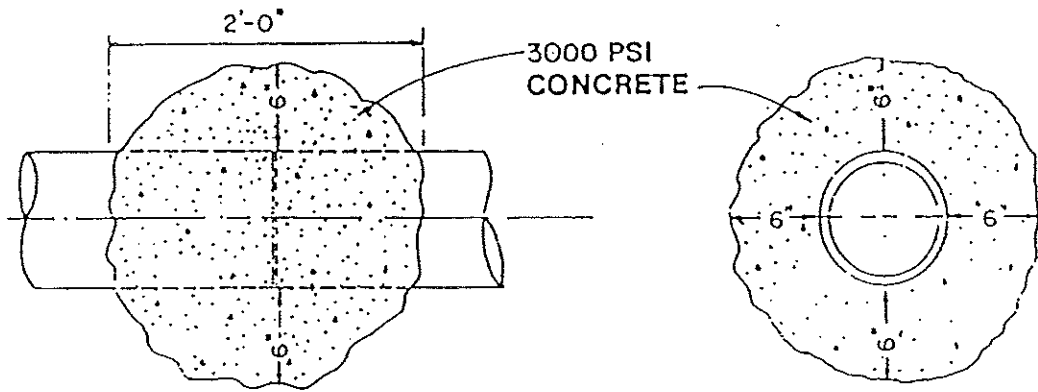

CONCRETE ANCHORING

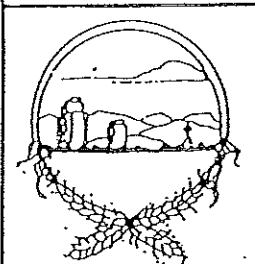

ANCHORING DETAIL

Town of Bennett

Issued: _____

Revised: _____

Drawing No.
W-29

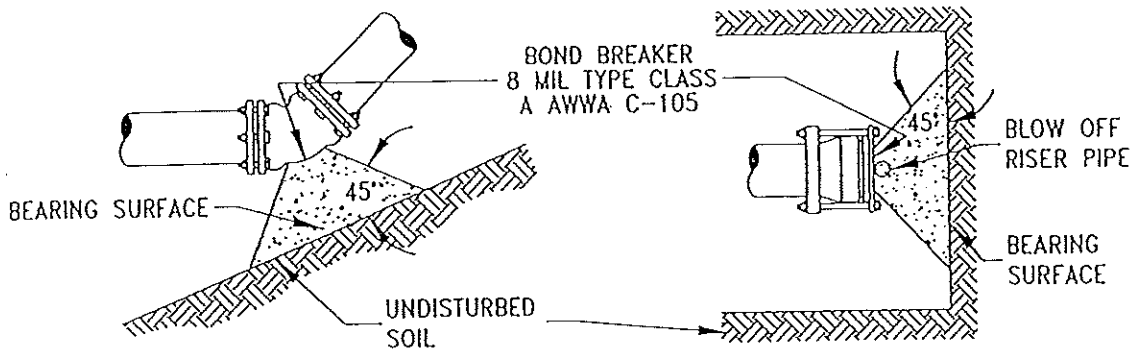

11 1/4, 22 1/2 & 45 BENDS

DEAD END

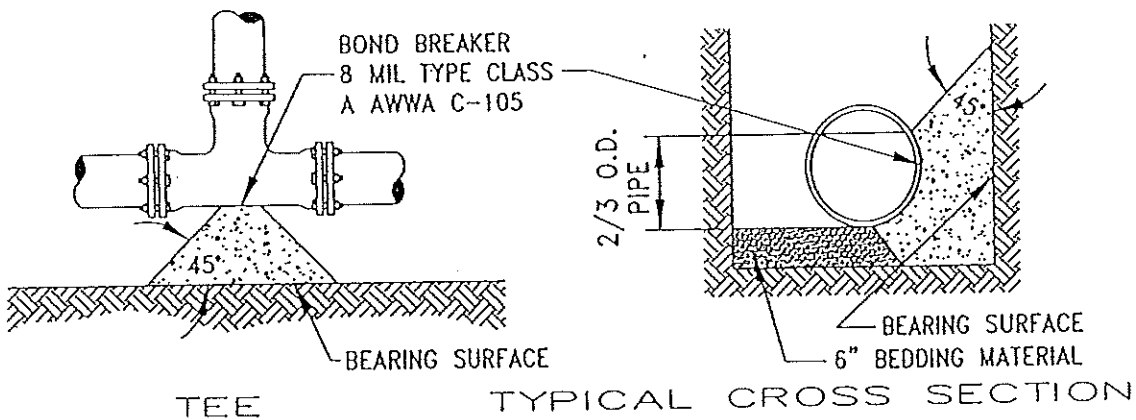

MINIMUM BEARING SURFACE AREA
(IN SQUARE FEET)

SIZE OF PIPE	BENDS				TEE OR DEAD END
	11 1/4"	22 1/2"	45°	90°	
6"	2.00	2.00	2.25	4.25	3.00
8"	2.00	2.00	4.00	8.00	5.25
12"	2.00	4.25	8.25	12.00	11.00
16"	3.50	6.50	12.50	23.00	16.50
20"	5.00	10.00	19.50	35.50	25.00

NOTES:

- BEARING AREAS SHOWN ON THE CHART ARE MINIMUM AREAS & ARE DESIGNED USING THE FOLLOWING CRITERIA:
 - INTERNAL WORKING PRESSURE OF 150 PSI.
 - TRANSIENT (WATER HAMMER) PRESSURE OF 120 PSI FOR 4", 6" & 8" DIAMETER LINES, 110 PSI FOR 12" LINES, & 70 PSI FOR 20" LINES.
 - THRUSTBLOCK CONCRETE SHALL HAVE A MINIMUM STRENGTH OF 3000 PSI.
- ALL SIZES OF BENDS, TEES & DEAD ENDS SHALL HAVE CONCRETE THRUSTBLOCKS.

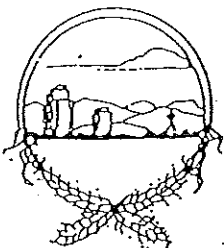

HORIZONTAL BEND THRUSTBLOCKS

Town of Bennett

Issued: _____

Revised: _____

Drawing No. _____

W-30

GALVANIZED  RODS, SEE CRITERIA BELOW

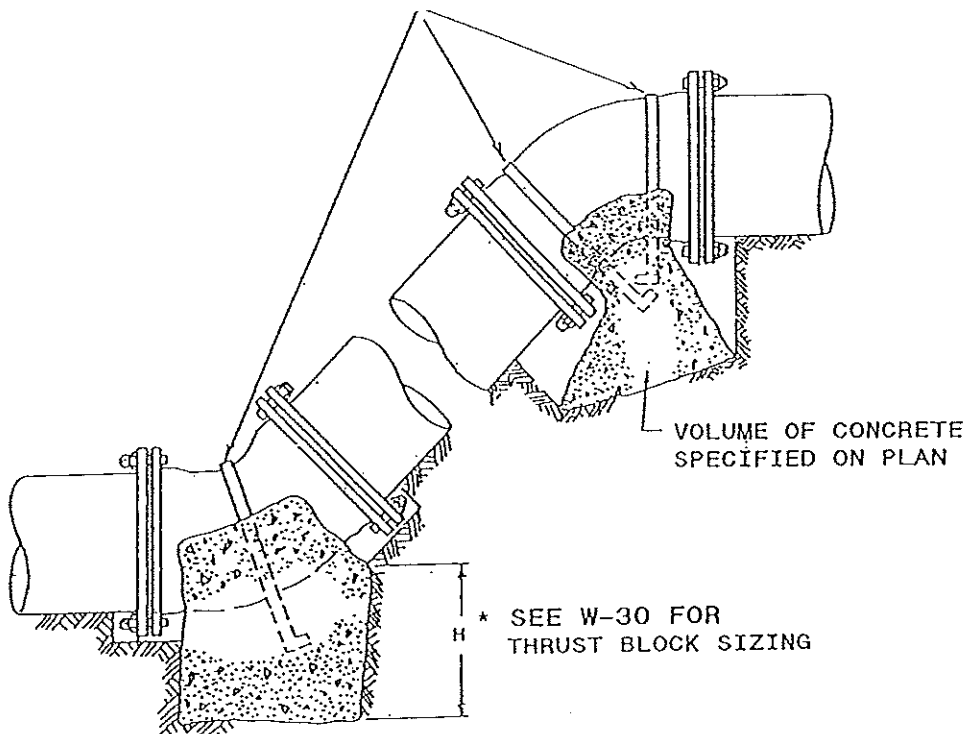

CRITERIA FOR GALVANIZED  RODS

Fitting Size (inches)	Rod Size	Embedment (inches)
12 and less	# 6	30
14 - 24	# 8	36
30 - 36	# 10	42

1. KEEP CONCRETE CLEAR OF JOINT AND ACCESSORIES.
2. REQUIRED VOLUMES AT FITTINGS SHALL BE AS INDICATED ABOVE, ADJUSTED IF NECESSARY TO CONFORM TO THE TEST PRESSURE(S) STATED IN THE SPECIFICATIONS.
3. THRUST BLOCKS FOR VERTICAL UP-BENDS SHALL BE THE SAME AS FOR HORIZONTAL BENDS.
4. ALL BURIED PIPING, EXCEPT FLANGED, SCREWED, SOCKET WELD PVC, OR WELDED STEEL PIPE, SPECIFIED TO BE PRESSURE TESTED, SHALL BE PROVIDED WITH CONCRETE THRUST BLOCKS AT ALL DIRECTION CHANGES, UNLESS OTHERWISE NOTED.
5. THRUST BLOCKS SHALL NOT BE LOCATED OR SIZED TO ENCASE ADJACENT PIPES OR FITTINGS.
6. ABOVE VOLUMES BASED ON TEST PRESSURE OF 150 PSI AND THE WEIGHT OF CONCRETE = 4,050 LBS/CU YD. TO COMPUTE VOLUMES FOR DIFFERENT TEST PRESSURES, USE THE FOLLOWING EQUATION: VOLUME = (TEST PRESSURE/150) X (TABLE VALUE).

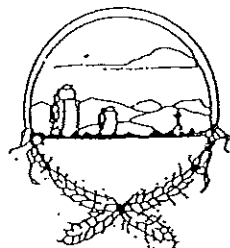

TYPICAL VERTICAL BEND ANCHORS

Town of Bennett

Issued: _____

Revised: _____

Drawing No.

W-31

PIPE SIZE INCHES	12" AND LESS	14" AND 16"
NUMBER OF RODS	2	4

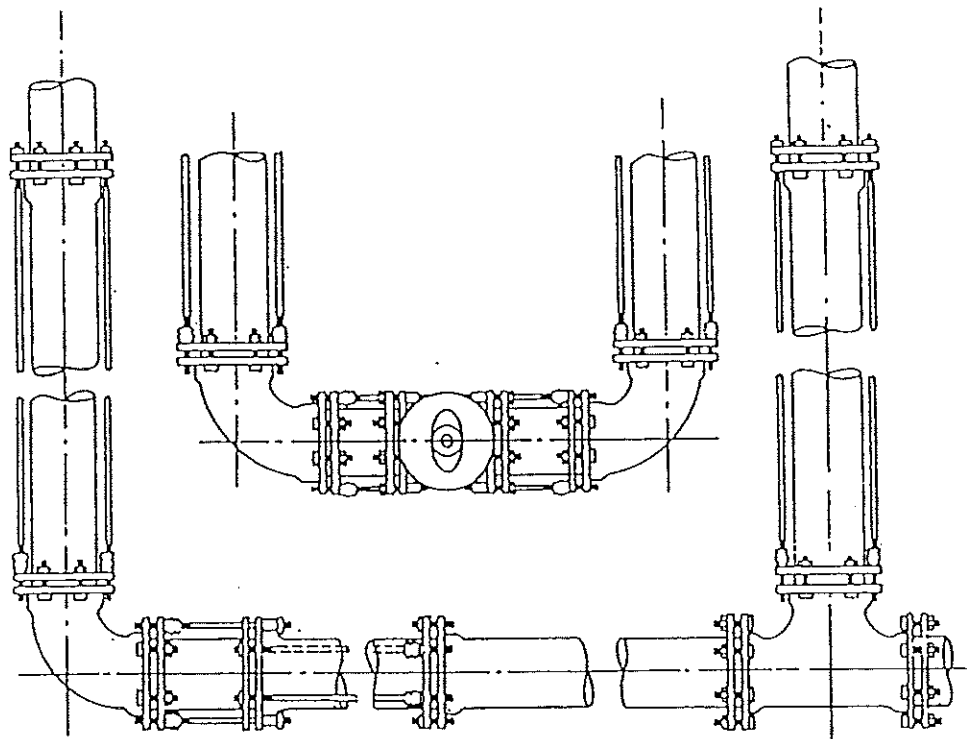

NOTE:

1. TIE-RODS WITH MECHANICAL JOINT PIPE WILL BE AS SHOWN ABOVE. IN LIEU OF MECHANICAL JOINT RODDING SYSTEM, SOCKET CLAMPS AND RODS, DUCTILE IRON RETAINER GLANDS WITHOUT RODS, OR DOUBLE MECHANICAL JOINT WITHOUT RODS, AS DESCRIBED IN THESE DETAILS, MAY BE USED WHERE RODS AND CLAMPS ARE SPECIFIED.
2. ROD DIA. SHALL BE 7/8" FOR 6' AND 8' PIPE, 1" FOR 10' AND 12' PIPE, 1-1/8" FOR 14' AND 16'.

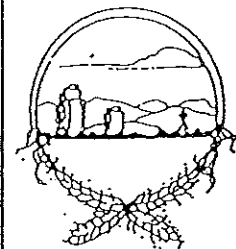

ROD and CLAMP DETAIL

Town of Bennett

Issued: _____

Revised: _____

Drawing No.
W-32

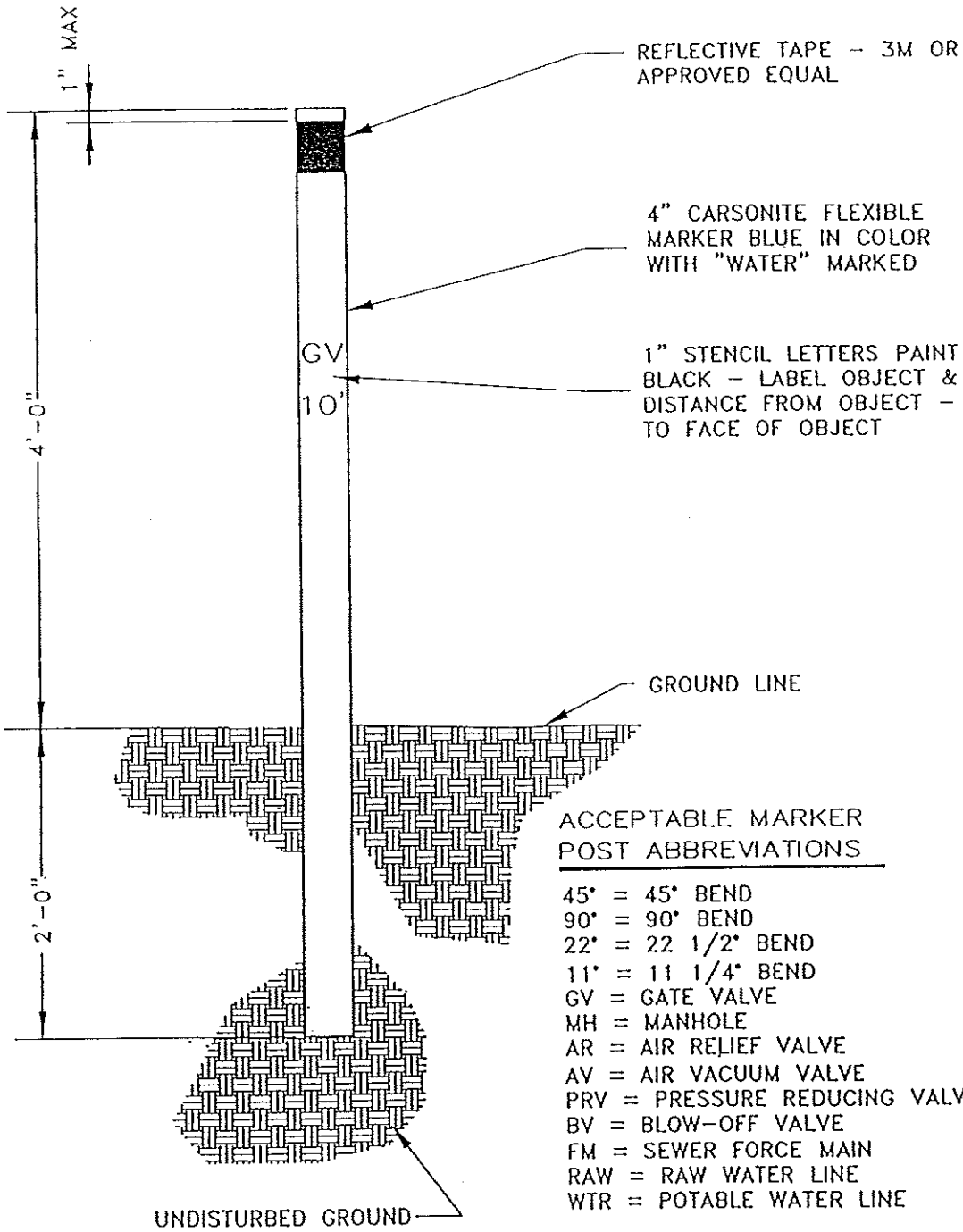

ACCEPTABLE MARKER POST ABBREVIATIONS

- 45° = 45° BEND
- 90° = 90° BEND
- 22° = 22 1/2° BEND
- 11° = 11 1/4° BEND
- GV = GATE VALVE
- MH = MANHOLE
- AR = AIR RELIEF VALVE
- AV = AIR VACUUM VALVE
- PRV = PRESSURE REDUCING VALVE
- BY = BLOW-OFF VALVE
- FM = SEWER FORCE MAIN
- RAW = RAW WATER LINE
- WTR = POTABLE WATER LINE

NOTE:

1. USE MARKER POST IN AREAS WHERE UTILITY CANNOT BE LOCATED FROM OTHER IMPROVEMENTS.

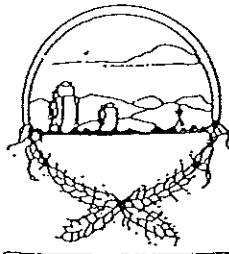

MARKER POST

Town of Bennett

Issued: _____

Revised: _____

Drawing No.

W-33

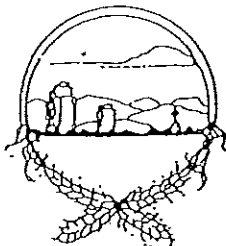
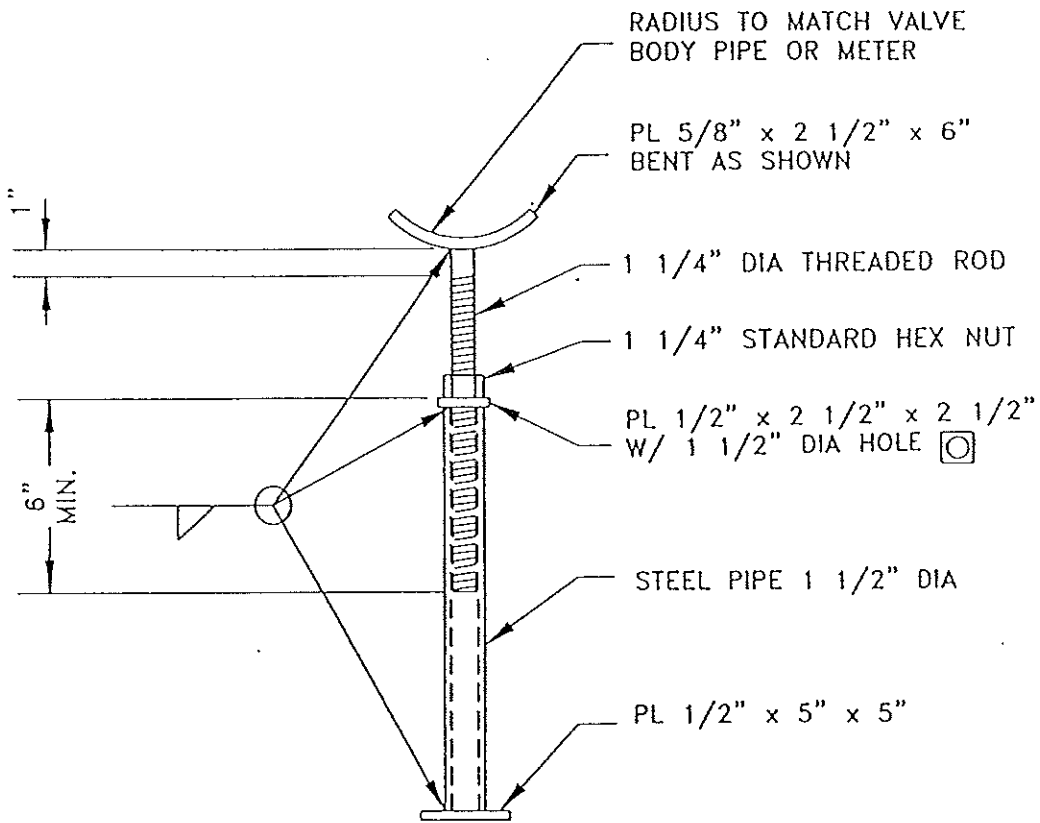

ADJUSTABLE PIPE SUPPORT

Town of Bennett

Issued: _____

Revised: _____

Drawing No.

W-34

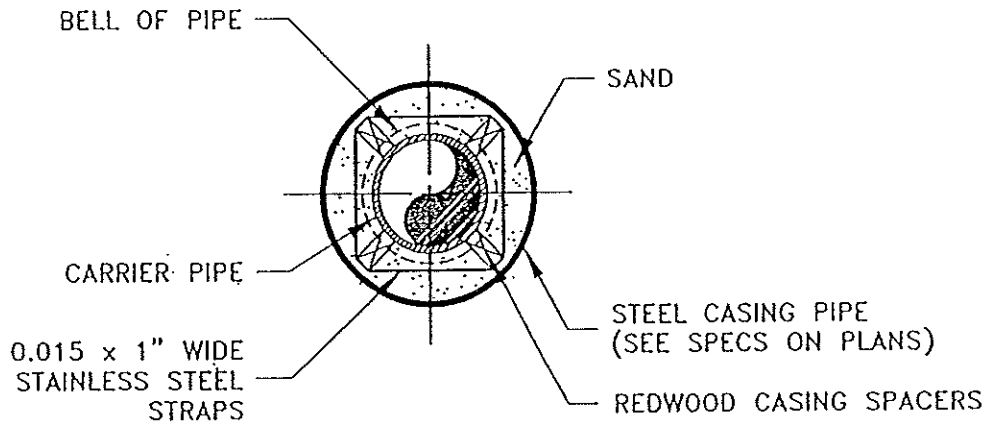
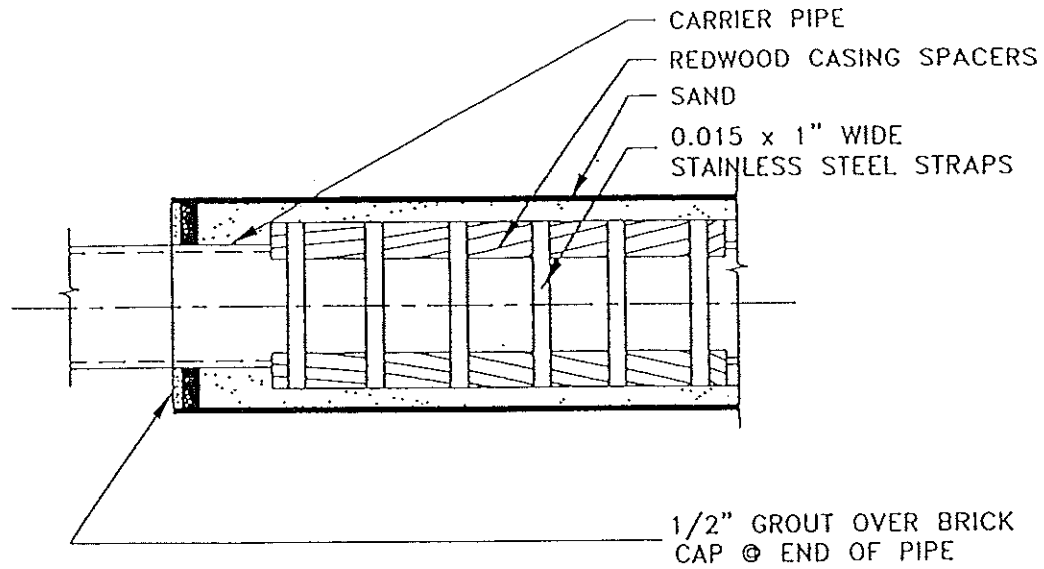

CARRIER PIPE NOMINAL DIA.	CASING PIPE		MINIMUM RUNNER SIZE
	MINIMUM O.D.	MINIMUM WALL THICKNESS	
4"	12"	0.188"	2" x 4"
6"	16"	0.250"	2" x 4"
8"	18"	0.282"	2" x 4"
12"	22"	0.344"	2" x 4"
16"	28"	0.406"	2" x 6"
20"	32"	0.469"	2" x 6"

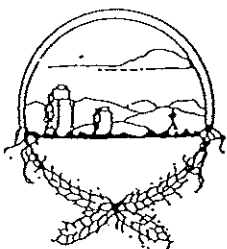

PIPE CASING & SLED DETAIL

Town of Bennett

Issued: _____

Revised: _____

Drawing No.

W-35

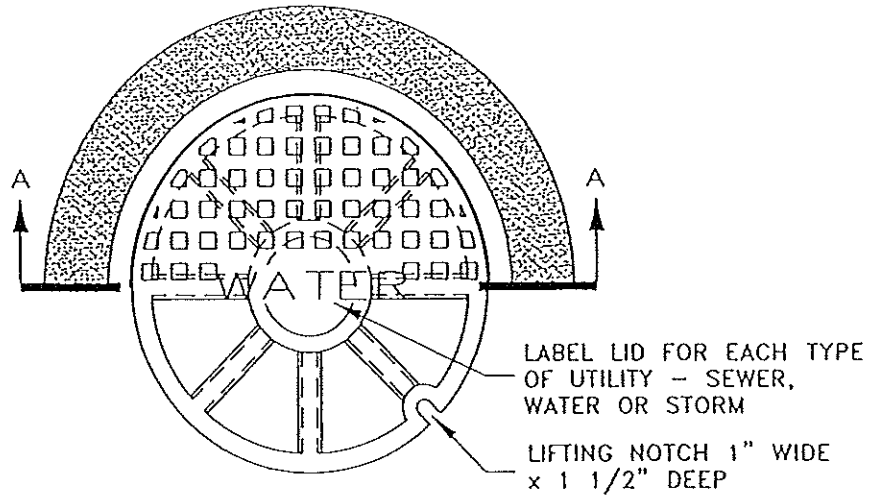

HALF PLAN

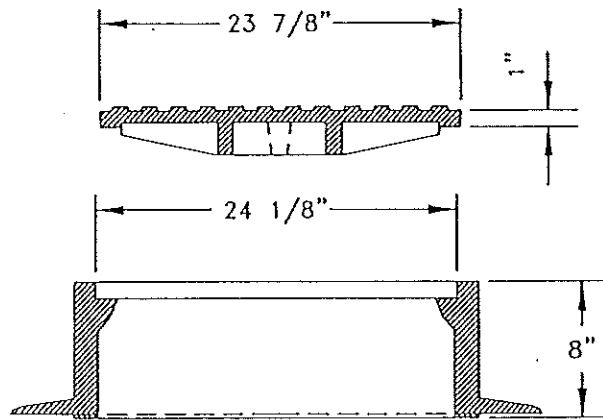

SECTION A - A

NOTES:

1. CASTING SPECIFICATIONS: ASTM A-48 WITH A MINIMUM TENSILE STRENGTH OF 30,000 PSI (CLASS 30). (NEENAH TYPE R-1706 RING & COVER OR EQUIVALENT).
2. TOTAL MINIMUM WEIGHT APPROXIMATELY 410 LBS.
3. DO NOT USE IN APPLICATIONS WHERE MANHOLES ARE WITHIN DRAINAGE WAYS.
4. STANDARD MANUFACTURER'S LETTERING SIZES & PATTERNS. (LETTERING SHALL BE CAST AS PART OF COVER).

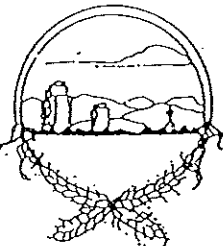

24" MANHOLE RING & COVER

Town of Bennett

Issued: _____

Revised: _____

Drawing No.

W-36